

1. OPERATIONAL DETAILS

The MPRX-16 and MPRX-8 are Return Path Receivers with an integrated 16/8-way splitter located on the RF output of the Receiver. The integrated splitter allows for maximized rack space when many receivers are mounted in the same chassis. The MPRX-16 and MPRX-8 receivers are dual-width and take up two slots in the MAXNET II Chassis. They are powered through a hot-swapping backplane in the chassis. The MPRX-16 and MPRX-8 modules feature the standard MAXNET II functionality including high-density packaging through the use of "MCX" cable connectors in conjunction with RG-sub miniature 59/u coaxial cable. Also featured are: front access alarm indicators, -20 dB test points and the capability of module status monitoring through any SNMP based (HMS Compliant) Manager. Refer to the MP3 Chassis User Manual for lists of all supported HMS MIBs and the various SNMP interface options available.

Functional Diagram

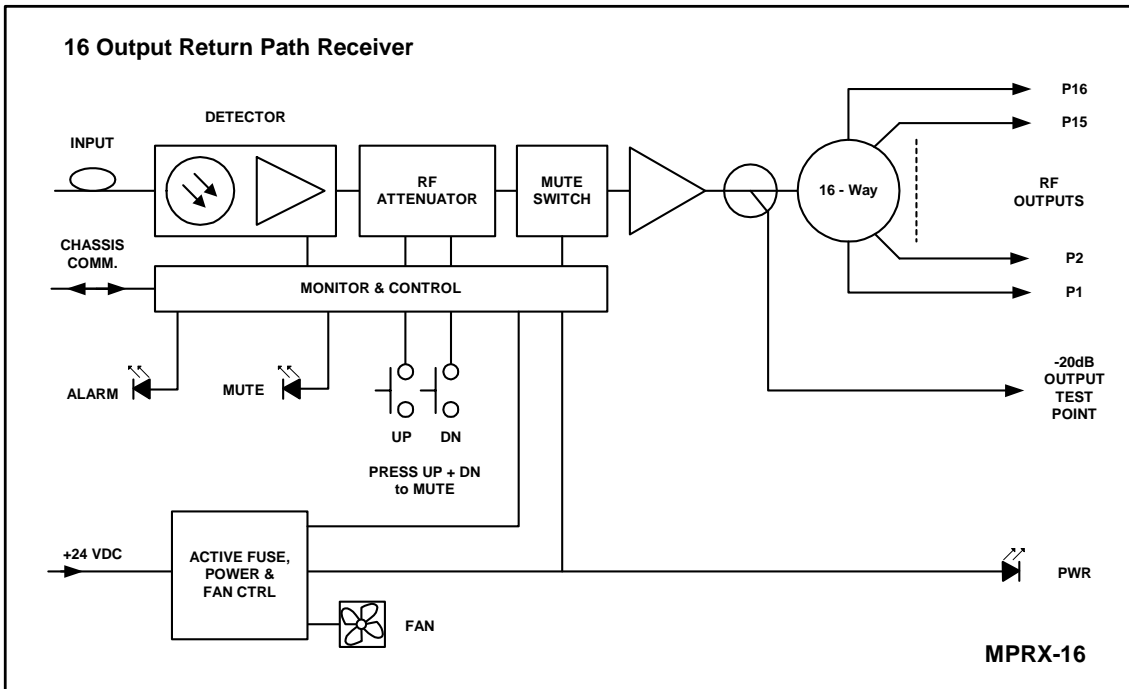



2. INSTALLATION

Module Installation into the MAXNET II Chassis

Slide the dual-width receiver module into an open slot that spans two module locations beginning with an odd number. The module will drop into the chassis into a positive lock position. If the module is installed properly, the receiver will make contact with the 24 VDC power bus in the chassis. If there is an active MAXNET II Power Supply Module installed in the chassis, the receiver module's LED 'Power' indicator will light green.

Optical Connections

Before removing the dust cap from the receiver's SC/APC bulkhead connector, clean the SC/APC ferrule on the optical jumper cable that will eventually connect to the receiver module. This can be done using a commercial cleaning tape or isopropyl alcohol, lint free tissues and compressed air. Never use compressed air on the MAXNET II Receiver's SC/APC bulkhead. Once the optical jumper cable's ferrule has been cleaned, it is recommended that you measure the optical power using an optical power meter. To prevent damage to the optical detector, the optical input power level should not exceed +3 dBm. Using build-out optical attenuators attenuate the measured optical input power to a level between +1 and -1 dBm. Verify the actual received power through the desired SNMP Interface.



3. RF CONNECTIONS

The RF output jacks on the receiver's rear panel are MCX [female]. There will be 16 (MPRX-16) or 8 (MPRX-8) outputs plus one front panel -20 dB test point. Connect a test jumper from one of these ports to a signal level meter or spectrum analyzer. Ensure that all unused RF outputs are terminated with 75-ohm MCX terminators.

The RF output level is proportional to the received optical input level. The operator can attenuate the RF output level by up to 31.5 dB, in 0.5dB increments and mute it completely if necessary. Adjust the receiver RF output level using the set-up below as a guide.

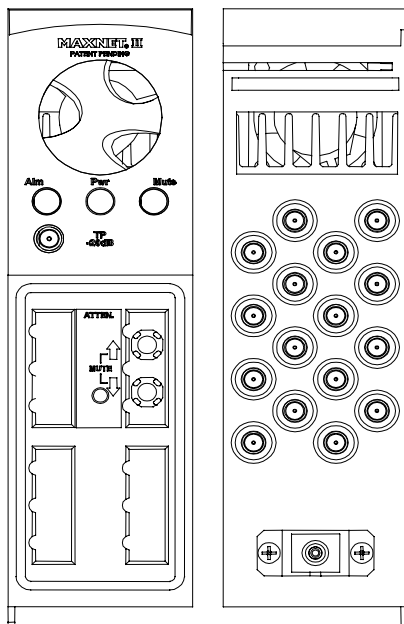

4. RECEIVER RF SET-UP

LED Indicators

The Return Path Receiver has three LED Indicators, Power, Alarm and Mute. The Power LED Indicator verifies that the receiver module is receiving power from the MAXNET II Power Supply through the 24VDC Chassis Bus. The Alarm LED Indicator will flash Red if there is a problem with the receiver or if any of the monitored functions are beyond the specified limits. The Mute LED Indicator will light amber if the receiver RF output is muted.

Receiver Pushbutton Switches

Remove the access cover from the front of the receiver module by turning the thumbscrew counter-clockwise. This will expose two pushbutton switches labelled UP and DOWN.

To adjust the RF Output Attenuator:

Press the UP or DOWN pushbuttons to adjust the RF output level of the receiver within a 30 dB range. Monitor the Output level changes at the -20dB RF Output Test Point. (Ensure that all unused RF outputs are terminated with 75-ohm MCX terminators.)

To Mute the Receiver's RF output:

Press both UP and DOWN pushbuttons at the same time and the Receiver RF output will be muted as indicated by the 'AMBER' LED indicator.

SINGLE RECEIVER				
LED \ STATUS	Green Steady	Red Flashing	Amber Steady	Off
POWER [Green]	Power On	NA	NA	Check Power Supply
ALARM [Red]	NA	Module problem	NA	Normal
MUTE [Amber]	NA	NA	Receiver RF Muted	Normal

* Note: If the red alarm LEDs are flashing at a slow rate of approximately 1s on : 1s off, this is indicative of a communications failure. Try pulling and replacing the module to clear, or else contact ATX.



5. MAINTENANCE

Monthly, vacuum all module cooling fans.

If SNMP monitoring is not used:

Daily, ensure that the Power LED's are on for all of the modules and that there are no Alarm lights.

Weekly, ensure that all module cooling fans are operational and unobstructed.

Fan Removal

If a fan fault alarm occurs, it may be necessary to replace the small fans on the front of the module. Loosen the two screws located above the LED's just enough to free the fan cover. Pull the cover outwards, using pressure on the screws to pull the fan out at the same time. Disconnect the 2 pin jumper and replace with a new fan (available from ATX) ensuring that red and black wires align. Push the excess wire into the heatsink with your fingers and insert the fan. Do not over-tighten the fan screws, as this will cause the fan to be pinched and you will hear a buzzing sound.

6. SERVICE AND SUPPORT

Contact ATX Networks

Please contact ATX Technical Support for assistance with any ATX products. Please contact ATX Customer Service to obtain a valid RMA number for any ATX products that require service and are in or out-of-warranty before returning a failed module to the factory.

ATX Networks
1-501 Clements Road West
Ajax, ON L1S 7H4 Canada

Toll Free: 1-800-565-7488

Fax: 905-427-1964

Web: www.atxincorporated.com

Warranty Information

All of ATX's Active modules have a 1-year warranty that covers manufacturer's defects or failures.

Safety

IMPORTANT! FOR YOUR PROTECTION, PLEASE READ THE FOLLOWING:

WATER AND MOISTURE: Care should be taken so that objects do not fall and liquids are not spilled into the enclosure through openings.

POWER SOURCES: The device should be connected to a power supply only of the type described in the operating instructions or as marked on the device.

GROUNDING OR POLARIZATION: Precautions should be taken so that the grounding or polarization means of the device is not defeated.

POWER CORD PROTECTION: Power supply cords should be routed so that they are not likely to be pinched by items placed upon or against them, paying particular attention to cords at plugs, convenience receptacles, and the point where they exit from the device.

SERVICING: The user should not attempt to service the device beyond that described in the operating instructions. All other servicing should be referred to qualified service personnel.

FUSING: If your device is equipped with a fused receptacle, replace only with the same type fuse. Refer to replacement text on the unit for correct fuse type.