



---

**MAXNET® II**

*Platinum Series*

Pat.# U.S. 7,142,414

**MPRX2-8**

**Dual Return Path Optical Receiver Manual**



# TABLE OF CONTENTS

	<b>Page</b>
<b>1. PRODUCT DESCRIPTION .....</b>	<b>1-1</b>
1.1. Functional Diagram .....	1-1
1.2. Technical Specifications .....	1-2
<b>2. INSTALLATION .....</b>	<b>2-1</b>
2.1. Product Inspection .....	2-1
2.2. Module Installation into the Active MAXNET® II Chassis .....	2-1
2.3. Optical Connections .....	2-1
2.4. RF Connections .....	2-2
2.5. Receiver Set-up .....	2-2
<b>3. STATUS MONITORING .....</b>	<b>3-1</b>
3.1. Chassis Interface Options .....	3-1
3.2. SCTE HMS MIB Software Definition of Module .....	3-1
3.3. Web Interface .....	3-1
3.4. Updating Active Chassis Firmware .....	3-2
3.5. Factory Reset .....	3-2
<b>4. STATUS MONITORING FEATURES .....</b>	<b>4-1</b>
4.1. SNMP Parameters .....	4-1
4.2. SNMP MIBs Required .....	4-2
<b>5. MAINTENANCE &amp; TROUBLESHOOTING .....</b>	<b>5-1</b>
5.1. Maintenance .....	5-1
5.2. Troubleshooting .....	5-1
<b>6. SERVICE &amp; SUPPORT .....</b>	<b>6-1</b>
6.1. Contact ATX Networks .....	6-1
6.2. Warranty Information .....	6-1
6.3. Safety .....	6-1

# Index of Figures and Tables

## **Figures**

#1 Dual Return Path Optical Receiver Functional Diagram .....	1-1
#2 Front & Rear Panel Pictures .....	2-1
#3 Front Panel Pushbuttons .....	2-3

## **Tables**

#1 Ordering Information.....	1-1
#2 Technical Specifications .....	1-2
#3 LED Status Indications .....	2-2
#4 Common Module SNMP Parameters .....	4-1
#5 MPRX2-8 SNMP Parametersd .....	4-1
#6 General SCTE HMS MIBs Required .....	4-2

# PRODUCT DESCRIPTION

## 1. Product Description

The MPRX2-8 MAXNET II module is a Dual Return Path Optical Receiver with an integrated 8-way splitter on each receiver's RF output. The integrated splitter allow for maximized rack space saving when many receivers are mounted in the same chassis. The MPRX2-8 receiver is dual-width, taking up two slots in the Active MAXNET II Chassis and is powered through a hot-swapping backplane in the Active MAXNET II Chassis. An appropriate MAXNET II Power Supply in the Active MAXNET II Chassis powers these modules. The MPRX2-8 module features the standard MAXNET II functionality including high-density packaging through the use of MCX coaxial cable connectors in conjunction with Mini RG-59 Type coaxial cable. Also featured are: front access alarm/status LED indicators, two -20 dB test points and the capability of module status monitoring through SNMP based Managers. The MAXNET II SNMP interface is HMS compliant.

Please refer to the web page for up-to-date specifications – [www.atxnetworks.com](http://www.atxnetworks.com)

Part Number	Description
MPRX2-8	Dual RPR with 8 RF Outputs per RPR

Table #1: Ordering Information

### 1.1. Functional Diagram

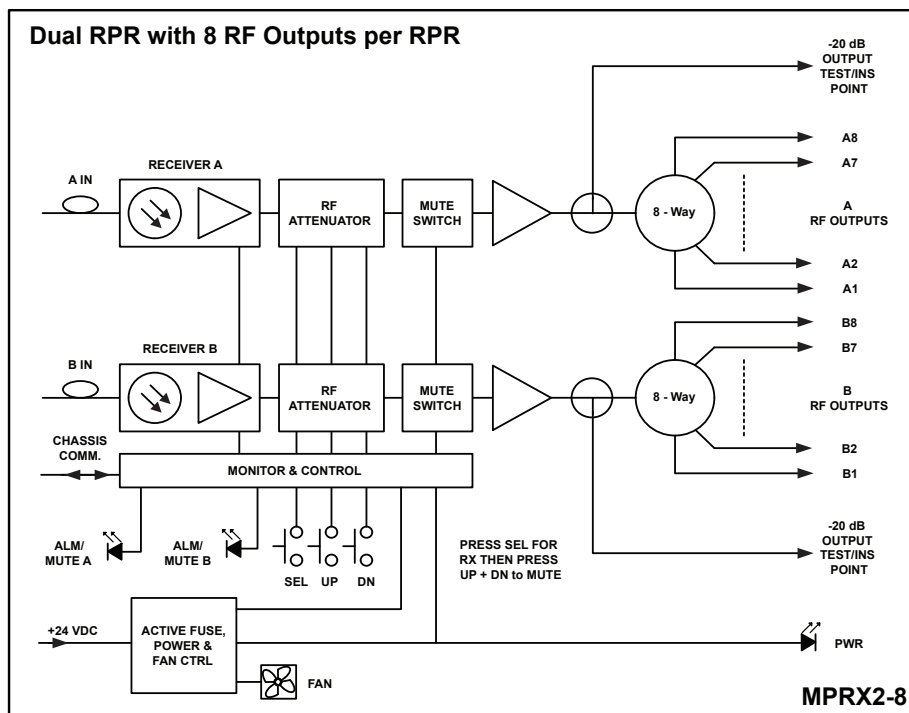

Figure #1: Dual Return Path Optical Receiver Functional Diagram

## 1.2. Technical Specifications

SPECIFICATIONS	MPRX2-8
<b>OPTICAL</b>	
WAVELENGTH	1200 - 1620 nm
INPUT POWER	-20 to +3 dBm
OPTICAL RETURN LOSS (Min)	45 dB
CONNECTOR TYPE	SC/APC (std.), Others on Special Order
<b>RF OUTPUT PERFORMANCE</b>	
BANDWIDTH	5 - 250 MHz
NOMINAL OUTPUT LEVEL <sup>(1)</sup>	25 +/- 2.0 dBmV
RESPONSE FLATNESS	+/- 0.5 dB / 6 MHz
RF TEST POINT (Relative to RF Out)	-10.0 +/- 1.0 dB
RF OUTPUT LEVEL ADJUST	31.5 dB in 0.5 dB increments (common path and per port as shown in schematic) Front Access Pushbutton, HMS SNMP v2c, Web Browser, Proprietary Network Interface
PORT TO PORT ISOLATION	> 30 dB, 5-250 MHz
RX TO RX ISOLATION	> 70 dB, 5-85 MHz
	> 60 dB, 85-200 MHz
RECEIVER MUTE (ISOLATION)	> 58 dB, 200-250 MHz
	> 70 dB, 5-85 MHz > 60 dB, 85-250 MHz Front Access Pushbutton, HMS SNMP v2c, Web Browser, Proprietary Network Interface
RX SWITCH CONTROL <sup>(2)</sup>	N/A
SECOND ORDER DISTORTION <sup>(3)</sup>	> 60 dBc
THIRD ORDER DISTORTION <sup>(3)</sup>	> 60 dBc
OUTPUT RETURN LOSS	20 dB
<b>OTHER</b>	
RECEIVER STATUS INDICATION	Front LEDs, HMS SNMP v2c, Web Browser, Proprietary Network Interface
CURRENT <sup>(4)</sup>	520mA
<b>NOTES:</b> (1) -9 dBm and 7% OMI per channel, no RF attenuation. Level shown is after 8-way splitter. (2) Redundant RPR switch position can be manual or automatic. Automatic control is based on user defined received optical power threshold settings. (3) Two laser test: -3 dBm and 40% OMI per laser. Measurement made with 40 dBmV carrier level at internal receiver output, before any splitting circuitry. (4) DC current required from 24V chassis bus.	

**Table #2: Technical Specifications**

# INSTALLATION

## 2. Installation

### 2.1. Product Inspection

Carefully unpack the receiver module from the shipping box. If the box or receiver module is damaged, please notify the freight company to make a damage claim. If you suspect that there is a problem with the receiver module that may affect its safe operation, do not install such a suspect Receiver into the Active MAXNET II Chassis.

### 2.2. Module Installation into the Active MAXNET® II Chassis

Slide the dual-width receiver module into an open slot in the Active MAXNET II Chassis, one that spans two single-width module locations beginning with an odd number (indicated by a white marker on the chassis), until the module drops into its lock position. The module must be inserted into an odd number slot in order for the receiver module to properly mate to the active chassis back plane. If the module is installed properly, the receiver will make contact with the 24 VDC power bus in the chassis and if there is a MAXNET II Power Supply Module installed in the chassis, and it is plugged into the respective power source, the module's PWR (Power) LED indicator will light green. To remove a receiver module from the chassis, gently lift the front handle and pull back on the module until it is clear of the chassis guide slot.

### 2.3. Optical Connections

Before removing the dust cap from the receiver's SC/APC bulkhead connector, clean the SC/APC ferrule on the optical jumper cable that will eventually connect to the receiver module. This can be done using a commercial cleaning tape or isopropyl alcohol, lint free tissues and compressed air. Never use compressed air on the MAXNET II Receiver's SC/APC bulkhead. Once the optical jumper cable's ferrule has been cleaned, it is recommended that you measure the optical power at its output using an optical power meter. To prevent damage to the MAXNET II Receiver's optical detector, the optical input power level into the Receiver Module should not exceed +3 dBm. Using optical attenuators, attenuate the measured optical input power to a level between 0 dBm and -14 dBm.

**CAUTION: DO NOT LOOK INTO THE SC/APC CONNECTOR AT ANY TIME AFTER REMOVING THE DUST CAP FROM THE RECEIVER'S SC/APC BULKHEAD CONNECTOR.**

Verify the actual received power using the chassis network connection and web-based monitoring locally with a computer connected to the chassis or through an SNMP Manager.



Figure #2: Front & Rear Panel Pictures

## 2.4. RF Connections

The RF jacks on the receiver’s front/rear panel are MCX [female]. There will be eight RF outputs plus one front panel 20 dB test point for Receiver A, and eight RF outputs plus one front panel –20 dB test point for Receiver B. The A and B test points are –20 dB relative to the A Rx and B Rx outputs respectively (see Functional Diagram). The A and B test points are –10 dB relative to the A RF and B RF outputs respectively. Connect a test jumper from each of these ports to a signal level meter or spectrum analyzer to verify signal quality and adjust RF levels before connecting subsequent equipment. Ensure that all unused RF outputs are terminated with 75-ohm MCX terminators.

The operator can attenuate the RF output level by up to 31.5 dB in 0.5 dB increments and mute the output completely if necessary. Both attenuation and mute of RF signals are performed independently and separately for receivers A and B.

## 2.5. Receiver Set-up

### 2.5.1. Dual Receiver LED Indicators

The MAXNET II MPRX2-8 Dual Return Path Optical Receiver has three LED indicators: PWR, A ALM/MUTE and B ALM/MUTE.

- a) The PWR (Power) LED verifies that the receiver module is receiving power from the MAXNET II Power Supply through the 24 VDC Chassis Bus. The PWR LED is always solid green when the module is powered. If no powering is available then the PWR LED is off. The PWR LED does not have a flashing condition.
- b) The A ALM/MUTE (Internal receiver A Alarm/Mute) LED will:
  - i) FLASH RED if there is a problem with receiver A or if any of its monitored functions are beyond the specified limits (e.g. absence of optical input signal at input A), and receiver A is not muted
  - ii) be SOLID ORANGE if receiver A’s RF output is muted
  - iii) ALTERNATE RED/ORANGE if the receiver A is muted and alarming
  - iv) be OFF when receiver A is not muted and works normally. Precondition though is that the PWR LED is GREEN.
- c) The B ALM/MUTE (Internal receiver B Alarm/Mute) LED works the same way for the receiver B parameters.

		STATUS				
		FLASHING RED <sup>1</sup>	SOLID ORANGE	ALTERNATE RED/ORANGE	SOLID GREEN	OFF
LED	PWR	N/A	N/A	N/A	Power ON	Check Power Supply
	A ALM/MUTE	Rx A problem	Rx A Muted	Rx A Muted and Alarm	N/A	Normal
	B ALM/MUTE	Rx B problem	Rx B Muted	Rx B Muted and Alarm	N/A	Normal

Table #3: LED Status Indications

<sup>1</sup> If the ALM LED is flashing red at a slow rate of approximately 1s on-1s off, this is indicative of a communications failure between this module and the chassis. See Troubleshooting section.

## 2.5.2. Dual Receiver Front Panel Pushbutton Switches & Controls

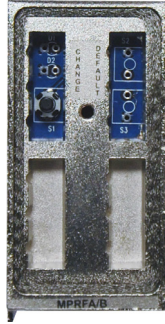

Figure #3: Front Panel Pushbutton

Remove the access cover from the front of the module by turning the thumbscrew counter-clockwise.

This will expose three pushbutton switches labelled  $\updownarrow$  (UP),  $\downarrow$  (DN/DOWN) and SEL (SELECT), and two LED's labelled A and B.

### 2.5.2.1. RF Attenuator Selection/Adjustment

Use the SELECT button to illuminate the desired receiver's LED. Press the UP or DOWN pushbuttons to adjust the RF output level of the selected receiver within a 31.5 dB range while monitoring the output level changes at the test point. Although the test point is 20 dB below the output of the receiver, the integrated splitters result in the RF level at the test point to be 10 dB below that of the RF output.

The UP/DOWN pushbuttons have to be pressed and released as many times as needed to set the desired level. Holding them pressed doesn't result in a continuous change of the attenuation value. Attenuation is adjustable from 0 to 31.5 dB in 0.5 dB steps. When adjusting and measuring RF levels ensure that all unused RF outputs are terminated with 75-ohm MCX terminators.

### 2.5.2.2. Muting the Receivers RF Output

Use the SELECT button to illuminate the desired receiver's LED. Press both UP and DOWN pushbuttons at the same time to mute the selected receiver's RF output. The corresponding A or B ALM/MUTE LED status indicator on the front panel of the MAXNET II module will light **orange**.

Repeat the same press to toggle the mute state, turning the receiver on and orange LED off.

This page left intentionally blank.

# STATUS MONITORING

## 3. Status Monitoring

### 3.1. Chassis Interface Options

The Active MAXNET II product line can be monitored and controlled in either of two ways:

- A free, web-based interface. This comes pre-installed on every chassis and provides a user friendly method of configuring the administrative set-up and all monitoring and control. It is based on SNMP, but requires little knowledge of SNMP. Any internet browser, such as Internet Explorer, is all the software that is required.
- Any third-party SNMP Management software (e.g. [www.castlerock.com](http://www.castlerock.com), [www.ndt-inc.com/SNMP/MIBrowser.html](http://www.ndt-inc.com/SNMP/MIBrowser.html)) may be purchased separately. These suites tend to be expensive and not as user friendly as the web interface. The web interface is also still required for administrative setup. The 3rd party interface is recommended only for systems that have an existing SNMP architecture. All MIBs (Management Information Bases) are freely downloadable from the SCTE ([www.scte.org/standards](http://www.scte.org/standards)). ATX was able to support all modules using the SCTE standard HMS MIBs, so no custom MIBs are required.

### 3.2. SCTE HMS MIB Software Definition of Module

The headend optical receiver MIB is used to provide RF attenuation and HI and LO alarm thresholds of each optical input. Both sides of this dual module are functionally separate from each other.

### 3.3. Web Interface

The MAXNET II chassis uses an integrated web page to supplement the SNMP management. All configuration of the chassis (static IP address, trap/email recipients, firmware upgrades, etc) must be done through the web page. Simply use any web browser (Internet Explorer, Firefox, etc) and enter the IP address of the chassis as the URL. Login as administrator to modify configuration and have full read/write access to monitor and control modules. Login as Operator to have full read/write access or login as observer to have read-only access. There is only one password per login level.

Parameter	Value	Properties																								
Model	MPRX2-8																									
Description	Dual Optical RPR with 8 RF Outputs per RPR																									
Name	Module in Slot 5																									
Manufacturer	ATX																									
Serial Number	DC-00-00-00-1B-13-DE-22																									
Hardware Rev	2.4																									
Firmware Rev	2.1																									
Temperature [C]	37.0	Analog																								
Alarm Detection Control	detectionEnabled																									
Voltage In [V]	23.5	Analog																								
Current In [mA]	528	Analog																								
Power In [W]	12.40	Analog																								
Fan Unit Status	normal	Discrete																								
<table border="1"> <thead> <tr> <th></th> <th>A Side</th> <th>B Side</th> </tr> </thead> <tbody> <tr> <td>Alias</td> <td><input type="text"/></td> <td><input type="text"/></td> </tr> <tr> <td>Asset ID</td> <td><input type="text"/></td> <td><input type="text"/></td> </tr> <tr> <td>OptRx Input Power [dBm]</td> <td>-2.4</td> <td>-2.7</td> </tr> <tr> <td>OptRx Input Wavelength [nm]</td> <td>1310.00</td> <td>1310.00</td> </tr> <tr> <td>OptRx Input Status</td> <td>normal</td> <td>normal</td> </tr> <tr> <td>OptRx Output Control (off=Mute)</td> <td>on</td> <td>on</td> </tr> <tr> <td>OptRx Output RF Attenuation [dB]</td> <td>0</td> <td>0</td> </tr> </tbody> </table>				A Side	B Side	Alias	<input type="text"/>	<input type="text"/>	Asset ID	<input type="text"/>	<input type="text"/>	OptRx Input Power [dBm]	-2.4	-2.7	OptRx Input Wavelength [nm]	1310.00	1310.00	OptRx Input Status	normal	normal	OptRx Output Control (off=Mute)	on	on	OptRx Output RF Attenuation [dB]	0	0
	A Side	B Side																								
Alias	<input type="text"/>	<input type="text"/>																								
Asset ID	<input type="text"/>	<input type="text"/>																								
OptRx Input Power [dBm]	-2.4	-2.7																								
OptRx Input Wavelength [nm]	1310.00	1310.00																								
OptRx Input Status	normal	normal																								
OptRx Output Control (off=Mute)	on	on																								
OptRx Output RF Attenuation [dB]	0	0																								

Save Changes

### 3.4. Updating Active Chassis Firmware

- a) Login to web page interface of the chassis as an administrator.
- b) Check software status page for current rev level. If an upgrade is necessary, proceed with next steps.
- c) Go to Firmware tab.
- d) Select 'HTTP Server' and verify it reads:  
[www.atxnetworks.com/firmware/MN2/image.bin](http://www.atxnetworks.com/firmware/MN2/image.bin)
- e) Select Upload and wait for confirmation page to appear. The chassis will perform an MD5 checksum on the downloaded file to verify that no bit errors occurred.
- f) If you are updating a version prior to 1.4.2, then the calculated MD5 Checksum will be displayed on the screen. Contact Engineering at ATX to verify what this value should be (it will be the same for each chassis you upgrade with a given revision).
- g) If you are updating a chassis later than 1.4.2, then the checksum is verified automatically via a text file taken from the ATX web server.
- h) If md5checksum is verified, select Flash to memory. **Do not flash if it fails the MD5 checksum**, as this could permanently corrupt the memory.
- i) Wait approximately 5 seconds, then disconnect the network cable and proceed to the next chassis. **Leave the recently updated chassis powered** until it completes a reboot.
- j) Optionally, the chassis may now be factory reset to restore all IP settings to factory defaults. Read the factory reset section fully before doing this to know what data will be lost when doing this.

### 3.5. Factory Reset

A factory reset will restore the chassis to the state which it left the ATX production facility.

#### 3.5.1. Parameters That Will be Changed

IP address = 192.168.0.1

Net Mask = 255.255.255.0

Gateway = 192.168.0.254

Passwords set to same text (but all lower case) as the login level. e.g. Operator password is operator.

All analogue and discrete alarm thresholds of modules will be reset to default values.

Alarm log will be cleared.

#### 3.5.2. Purpose

Common reasons for requiring a factory reset are:

- a) The chassis is unresponsive, or the IP address is not known.
- b) The Administrator password has been forgotten.
- c) The yellow COMM LED does not blink after the 2 minute boot cycle, even after a power cycle or press of the RESET button.

#### 3.5.3. Method

If you are sure you want to factory reset, hold down the RESET button near the RJ45 port for at least 10 seconds. The yellow COMM LED will be solid-on during this time, and once it turns off you can release the button and the reboot process will begin.

# STATUS MONITORING FEATURES

## 4. Status Monitoring Features

### 4.1. SNMP Parameters

Display Name	Description	HMS MIB Variable
Model	ATX model number (note, in empty slots you can enter passive, dual-passive, or empty to populate the overview page with passive picture placeholders).	entPhysicalModelName
Description	Description of the module.	entPhysicalDescr
Name	Indicates the slot of the chassis the module is in.	entPhysicalName
Alias	Optional user defined field - added to fifth variable binding of traps and emails e.g. set this to "Node 69" for a given Receiver and any alarms generated by this receiver will have "Node 69" in the description. Otherwise, it would only contain the IP address of the chassis, the Model and Name (slot number).	entPhysicalAlias
Manufacturer	ATX	entPhysicalMfgName
Asset I.D	Optional user settable field (suggestions: enter in a custom serial number or purchase order # for tracking).	entPhysicalAssetID
Serial No	Module's serial number.	entPhysicalSerialNum
Hardware Rev	Hardware rev of module.	entPhysicalHardwareRev
Firmware Rev	Firmware rev of module.	entPhysicalFirmwareRev
Temperature [C]	Module's current heatsink temperature.	heCommonTemperature
Alarm Detection Control	detectionEnabled: normal operation, with active alarms detectionDisabled: used to temporarily disable alarms/traps from this module detectionEnabledandRegenerate: enter detectionEnabled state while regenerating all alarm table entries	heCommonAlarmDetectionControl
Fan Unit Status	Alarm status of the fan.	heFanUnitAlarm

Table #4: Common Module SNMP Parameters

Display Name	Description	HMS MIB Variable
OptRx Input Power	Measured optical power input (max +3dBm).	heOpRxInputPower
OptRx Input Wavelength	Optional, user-settable integer to store the wavelength of operation. This value has no effect on the operation of the device.	heOpRxInputWavelengthControl
OptRx Input Status	If optical input power is beyond thresholds, this will be in <i>fault</i> condition.	heOpRxInputStatus
OptRx Output Control	Allows the user to mute the RF output.	heOpRxOutputControl
OptRx Output RF Attenuation	Control of RF output attenuation level (0-31.5 dB in 0.5 dB steps).	heOpRxOutputRFPadLevel
Voltage In [Volt]	Measured voltage supplied to the module from the chassis (nominally 24V).	hePsUnitVoltageIN
Current In [mA]	Current taken from the 24V rail by the module.	hePsUnitCurrentIN
Power In [Watts]	P.S. Voltage * P.S. Current	hePsUnitPowerIN

Table #5: MPRX2-8 SNMP Parameters

## 4.2. SNMP MIBs Required

	<b>HMS#</b>	<b>SCTE#</b>
SCTE-ROOT	028	36
SCTE-HMS-ROOTS	072	37
SCTE-HMS-HEADENDIDENT-MIB	114	38-11
SCTE-HMS-HE-COMMON-MIB	111	84-1
SCTE-HMS-PROPERTY-MIB	026	38-1
SCTE-HMS-HE-FAN-MIB	117	84-3
SCTE-HMS-HE-POWER-SUPPLY-MIB	116	84-2
SCTE-HMS-HE-OPTICS-MIB	108	83-1
SCTE-HMS-HE-OPTICAL-RECEIVER-MIB	113	85-2

**Table #6: General SCTE HMS MIBs Required**

# MAINTENANCE & TROUBLESHOOTING

## 5. Maintenance & Troubleshooting

### 5.1. Maintenance

Daily, ensure that the Power LED's are on for all of the modules and that there are no Alarm lights. Ensure that the yellow 'COM' LED near the rear RJ45 port is blinking.

Weekly, ensure that all module cooling fans are operational and unobstructed.

Monthly, vacuum all module cooling fans.

### 5.2. Troubleshooting

The following guide will help the operator to diagnose problems in active modules or chassis'. If none of the items in this section are of help, please contact ATX for Technical Support.

#### 5.2.1. Slow Flashing Red LED on Module Front

If any alarm LED on the front of the module is blinking at a rate of approximately 1 second ON, 1 second OFF, then this is indicative of a slot addressing communications failure. RF and Optical functionality will likely still work, but the unit will have no software monitoring or control during this time.

Try removing the module and replacing it. If this does not fix the problem, then switch the module to a different slot in the chassis. If the red LEDs return to normal operation, then the problem is in actual slot of the chassis and likely the connector on the back rail is damaged. Contact ATX and report a defective chassis.

If this does not fix the problem then contact ATX and report a defective module.

#### 5.2.2. Chassis' Yellow COM LED not Blinking

It is normal for the round LED near the RJ45 port at the rear of the chassis to be solid ON or OFF during various states of system boot-up. If the chassis has been powered up (solid green on the round "+24V" LED near the terminal block at the rear of the chassis) for at least 2 minutes, then the yellow LED should be blinking to indicate the chassis software is running. If it is not, a reboot is necessary.

If the chassis can be interrupted briefly, then simply remove power to it by pulling all MPAC/MPDC modules out part-way.

If the chassis must remain live then try pressing the black RESET button near the RJ45 port. If this does not work, then the communications module itself can be removed from the back of the chassis. Remove the two phillips screws that hold the module on, then pull it off and replace it. This will not interrupt the operation of the modules within the chassis.

If this still does not start the yellow LED blinking after boot-up, then a factory reset will be necessary. See Section 3.5.

#### 5.2.3. No Response from Chassis over Network

Typically, this is a 'subnet' issue. In order for any device to see another device on the same network, they must be on the same subnet. Consult your IT department for details of your network, but typically the subnet refers to the first three of the four octets in an IP address. E.g. if the computers in your network are given IP addresses of 192.168.10.1 through 192.168.10.250, then the subnet is the 192.168.10 part.

Each MAXNET II chassis ships with a default IP of 192.168.0.1, so the PC connected to it must have an IP address of 192.168.0.x where x is not equal to 1. This is not generally the case, so it must be forced.

To modify the PC's IP in Windows, choose Start -> Settings -> Network Connections -> Local Area Connection -> Properties -> Internet Protocol (TCP/IP).

If the chassis IP is no longer at the default IP, modify the subnet portions of these settings (IP address and Default Gateway) to match.

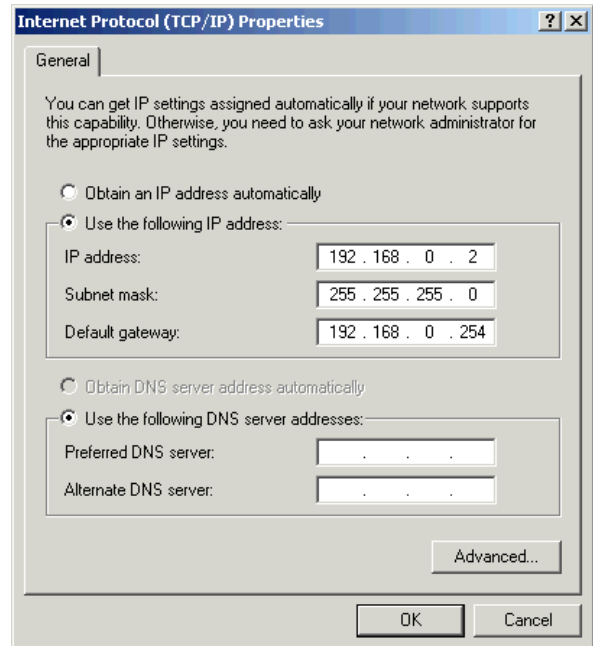

If the chassis is still not visible, it is possible the IP address of the chassis has been forgotten (see Factory Reset section), the network connection is not good (see Ethernet Port section for LED diagnostics) or a network port is blocked or firewalled (check with your IT department)

#### 5.2.4. Some Modules Do Not Show Up On Web Page

If the chassis is visible on the web or through SNMP walks, but one or more installed modules is not, try removing and replacing the module in a different slot. Verify that the green power LED is solid and the red LED is either off or blinking quickly (approx half second on, half second off). If the LED's are not as stated, see the appropriate troubleshooting section.

#### 5.2.5. Module Power LED Off or Intermittent

Check the '24V' green LED on the rear of the chassis. If it is off, then the problem is that the chassis is not getting power. See MPAC/MPDC troubleshooting section. If it is on or if other modules in the chassis are okay, the module itself is suspect. Continue.

Remove the suspect module and trade slot positions with another functioning module.

- a) If the suspect module is okay and the previously good module fails, contact ATX and report a defective chassis.
- b) If the suspect module fails and the previously good module is okay, contact ATX and report that the suspect module is defective.

#### 5.2.6. MPAC/MPDC not Powering Chassis

\*Note that 220 VAC applied to an MPAC-110 will damage the module, but 110 VAC applied to an MPAC-220 will simply not turn on.

- a) Check the fuse continuity on the MPAC or MPDC module.
- b) Verify that the 110 VAC / 220 VAC electrical outlet is active using a voltmeter and checking the circuit breaker. (In the case of the MPDC insure that there is -48 VDC on the rear terminal block).
- c) Verify that IEC power cord is properly inserted into the receptacle on the rear of the module and properly connected to a 110 VAC / 220 VAC electrical outlet.

### 5.2.7. Module will not Insert Fully into Chassis

- a) Remove the module and inspect it for damage or bent guide rails.
- b) Inspect the chassis for bent metal or obstructions.
- c) Be sure that the active module is inserted such that the left side is above an odd numbered slot and the right side is above an even number slot.
- d) Try the module in a different slot. Due to machinery tolerances, some modules may be more snug in some slots than others. If the tolerances are unacceptable, contact ATX.

### 5.2.8. Temperature/Fan Fault Alarm on any MAXNET® II Active Module

Check to see if the module fan is operating. If not replace with a new fan from ATX (Fan Part #: MPFANA) using the below procedure.



1. Remove two screws holding plate and fan in place.

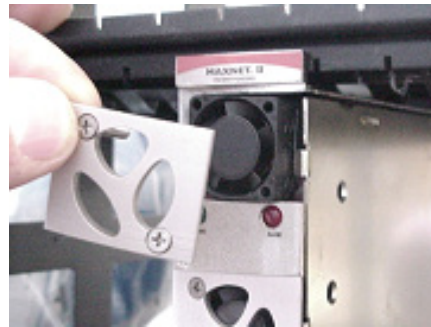

2. Remove fan cover and screws.



3. Pull out fan with tweezers.

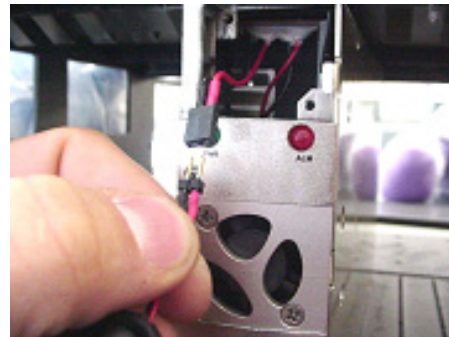

4. Remove push-fit power connections.

5. Install replacement fan in the opposite order shown. Ensuring that:
  - a) The red and black wires are aligned.
  - b) The labelled side of the fan faces inward toward the module
  - c) The wires do not bunch up behind the fan, interfering with fan rotation.

This page left intentionally blank.

## SERVICE & SUPPORT

### 6. Service & Support

#### 6.1. Contact ATX Networks

Please contact ATX Technical Support for assistance with any ATX products. Please contact ATX Customer Service to obtain a valid RMA number for any ATX products that require service and are in or out-of-warranty before returning a failed module to the factory.

ATX Networks  
1-501 Clements Road West  
Ajax, ON L1S 7H4 Canada

Tel: (905) 428-6068  
Toll Free: (800) 565-7488  
Fax: (905) 427-1964  
Toll Free Fax: (866) 427-1964  
Web: [www.atxnetworks.com](http://www.atxnetworks.com)  
E-mail: [support@atxnetworks.com](mailto:support@atxnetworks.com)

#### 6.2. Warranty Information

All of ATX Networks' products have a 1-year warranty that covers manufacturer's defects or failures.

#### 6.3. Safety

**IMPORTANT! FOR YOUR PROTECTION, PLEASE READ THE FOLLOWING:**

**WATER AND MOISTURE:** Care should be taken so that objects do not fall and liquids are not spilled into the enclosure through openings.

**POWER SOURCES:** The device should be connected to a power supply only of the type described in the operating instructions or as marked on the device.

**GROUNDING OR POLARIZATION:** Precautions should be taken so that the grounding or polarization means of the device is not defeated.

**POWER CORD PROTECTION:** Power supply cords should be routed so that they are not likely to be pinched by items placed upon or against them, paying particular attention to cords at plugs, convenience receptacles, and the point where they exit from the device.

**SERVICING:** The user should not attempt to service the device beyond that described in the operating instructions. All other servicing should be referred to qualified service personnel.

**FUSING:** If your device is equipped with a fused receptacle, replace only with the same type fuse. Refer to replacement text on the unit for correct fuse type.



1-501 Clements Road West, Ajax, ON L1S 7H4 Canada  
Tel +1 (905) 428-6068 Toll Free +1 (800) 565-7488 Fax +1 (905) 427-1964 Toll Free Fax +1 (866) 427-1964  
[www.atxnetworks.com](http://www.atxnetworks.com) [support@atxnetworks.com](mailto:support@atxnetworks.com)