



---

# **Q-SERIES<sup>®</sup> Optical**

## **QFOT1310 Series Broadcast Transmitter User Manual**



# TABLE OF CONTENTS

	Page
<b>1. PREFACE</b> .....	<b>1-1</b>
<b>2. OVERVIEW</b> .....	<b>2-1</b>
<b>3. FEATURES</b> .....	<b>3-1</b>
<b>4. FUNCTIONAL DIAGRAM</b> .....	<b>4-1</b>
<b>5. SPECIFICATIONS</b> .....	<b>5-1</b>
5.1. Link Test Condition .....	5-1
5.2. Specifications Table .....	5-1
5.3. Optical Link C/N Table .....	5-2
<b>6. FUNCTION GUIDE</b> .....	<b>6-1</b>
6.1. Front Panel Guide .....	6-1
6.2. Rear Panel Guide .....	6-1
6.3. Parameter Display .....	6-2
6.4. Alarm Indication .....	6-2
<b>7. INSTALLATION &amp; ADJUSTMENT</b> .....	<b>7-1</b>
7.1. Opening the Cover .....	7-1
7.2. Supplies & Tools .....	7-1
7.3. Installation .....	7-1
<b>8. SNMP MANAGEMENT</b> .....	<b>8-1</b>
8.1. IP Address .....	8-1
8.2. Setting Private IP Address .....	8-1
<b>9. CLEANING &amp; MAINTENANCE</b> .....	<b>9-1</b>
<b>10. AFTER-SALE CUSTOMER SERVICE</b> .....	<b>10-1</b>
<b>11. TROUBLESHOOTING</b> .....	<b>11-1</b>
<b>12. SERVICE &amp; SUPPORT</b> .....	<b>12-1</b>
12.1. Contact ATX Networks .....	12-1
12.2. Warranty Information .....	12-1

This page left intentionally blank.

# PREFACE

## 1. Preface

This manual is designed for QFOT1310 series 1310nm broadcast transmitter along with a detailed description of product features, specifications, installation, adjustments and troubleshooting. To install this transmitter successfully and use it safely, users must read the manual carefully before installation, and perform their installation and adjustments according to this manual. Otherwise, some practices may lead to property damage or personal injury. Please contact ATX Networks if you have any questions.

### Important User Information

- **Caution:** There are invisible laser beams from Fiber output ports, which may cause permanent injury to skin or eyes.
- Grounding first before turning on the power (grounding resistance should be less than  $4\Omega$ ), so as to prevent laser and user from static damaging.
- UPS power supply and air conditioned environment are highly recommended for the stable and long-time transmitter operation.

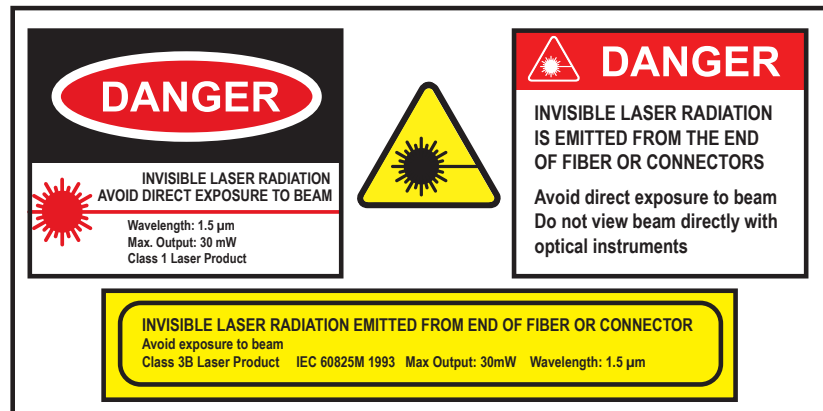

This page left intentionally blank.

## OVERVIEW

### 2. Overview

QFOT1310 is a 1310nm DFB laser transmitter delivering TV signals, digital TV signals, telephone voice signals and data signals over long distance fiber cable for CATV networks. The product utilizes a high performance cooled DFB laser as the light source, RF power digital automatic process technique, along with RF pre-distortion circuit. At the same time, a built-in microprocessor monitoring system automatically ensures the excellent performance of this transmitter.

This page left intentionally blank.

## FEATURES

### 3. Features

- High performance DFB laser with narrow spectrum and good linearity.
- RF power digital automatic processing technology.
- Excellent pre-distortion technology leading to the improved CTB, CSO and C/N.
- Built-in microprocessor controlling laser and RF performance.
- Front panel VFD screen displaying the transmitter status.
- 19" 1U standard rack with RS485 and RS232 ports for optional remote monitoring
- Optional Ethernet port for SNMP management

This page left intentionally blank.

# FUNCTIONAL DIAGRAM

## 4. Functional Diagram

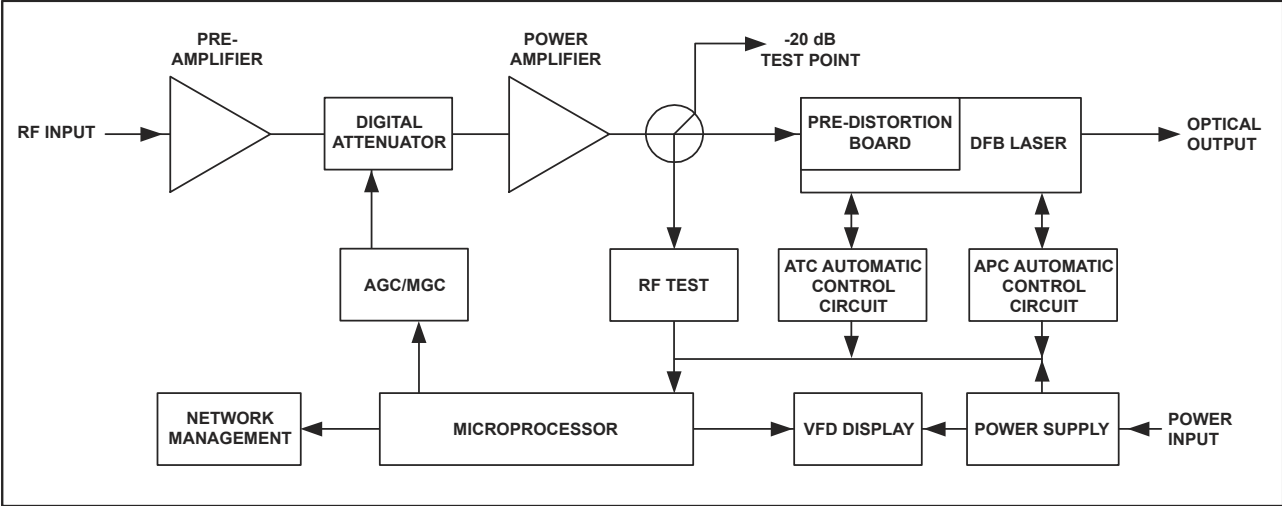

This page left intentionally blank.

# SPECIFICATIONS

## 5. Specifications

### 5.1. Link Test Condition

**Test Condition:**

Test link consists of the QFOT1310 transmitter, 10 Km standard fiber, attenuator and standard optical receiver. Input RF channels are 59 PAL-D channels (equivalent to 77 NTSC channels). The optical receiver input power is -1 dBm.

### 5.2. Specifications Table

SPECIFICATIONS	VALUE									
	4 mW	6 mW	8 mW	10 mW	12 mW	14 mW	16 mW	18 mW	20 mW	22 mW
OPTICAL LINK PATH LOSS	7 dB	9 dB	10 dB	11 dB	11.8 dB	12.5 dB	13 dB	13.6 dB	14 dB	14.4 dB
OPTICAL WAVELENGTH	1310nm +/- 20									
TYPE OF LASER	Cooled DFB in 14 pin butter-fly package with isolator									
OPTICAL MODULATION MODE	Direct Modulation									
OPTICAL CONNECTOR TYPE	SC/APC, Single mode									
FREQUENCY RANGE	45 to 862/1000 MHz									
RF INPUT LEVEL	15 to 25 dBmV									
FLATNESS IN BAND	+/- 0.75 dB									
RF INPUT IMPEDANCE	75 Ohm									
INPUT RETURN LOSS	≥ 16 dB from 45 to 862 MHz									
C/CTB	≥ 67 dB									
C/CSO	≥ 62 dB									
C/N	≥ 51 dB									
AGC CONTROL RANGE	+/- 15 dB									
MGC CONTROL RANGE	+/- 15 dB									
POWER VOLTAGE	100 to 240 VAC (50 to 60 Hz)									
POWER CONSUMPTION	20W									
OPERATION TEMPERATURE	0°C to +45°C (+32°F to +113°F)									
STORE TEMPERATURE	-20°C to +65°C (-4°F to +149°F)									
RELATIVE HUMIDITY	Max 95% Non-condensing									
DIMENSIONS	1.75"H x 17.0"W x 12.8"D (4.45H x 43.18W x 32.51D cm)									
WEIGHT	11.0 lbs (5.0 kg)									

### 5.3. Optical Link C/N Table

OPTICAL LINK PATH C/N SPECIFICATIONS																	
OPTICAL LOSS (dB)	4	5	6	7	8	9	10	11	12	13	14	15	16	17	18		
QFOT1310-04	53.8	52.8	51.8	51.0	50.1	49.2	48.2										
QFOT1310-06				53.0	52.0	51.0	50.1	49.1	48.1								
QFOT1310-08					52.8	51.9	51.0	50.1	49.1	48.2							
QFOT1310-10						52.9	51.9	51.0	50.1	49.1	48.2						
QFOT1310-12							52.7	51.8	50.8	49.9	49.0	48.0					
QFOT1310-14								52.4	51.5	50.5	49.5	48.6	47.8				
QFOT1310-16									52.0	51.0	50.1	49.1	48.1				
QFOT1310-18										52.5	51.6	50.6	49.7	48.7	47.9		
QFOT1310-20											51.9	51.0	50.0	49.0	48.0		
QFOT1310-22												52.2	51.4	50.4	49.4	48.6	47.8

## FUNCTION GUIDE

### 6. Function Guide

#### 6.1. Front Panel Guide

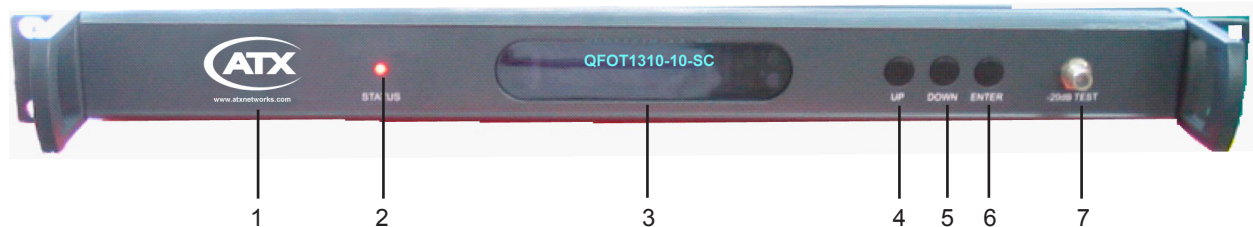

Front View

- 1 **ATX Trademark**
- 2 **LED Status Indicator:** Green light: normal; Red light: warning. Check VFD message to troubleshoot problem.
- 3 **VFD Monitor:** Displays each status parameter, product model, serial number and other information about this transmitter.
- 4 **UP Button:** Scroll the VFD display UP, or increase setting value.
- 5 **Down Button:** Scroll the VFD display DOWN, or decrease setting value.
- 6 **Enter Button:** MGC/AGC mode and MGC Attenuation Number mode select.  
**NOTE:** At “AGC Status”, pressing “Enter” would switch to “MGC Status”; at “MGC Status”, pressing “Enter” would switch to “AGC Status”. There are two ways to change the RF modulation level to the laser.  
 At “AGC Status”, press the UP or DOWN button until the VFD displays ‘**MOD LEVEL=XXdBmV**’, then press the “Enter” button to select. After selecting, the VFD will display ‘**MOD LEVEL=XXdBmV**’ and ‘**Please install...**’. At this point the user can change the modulation level in 1dB increments by pressing the UP or DOWN buttons. Once you have selected the desired modulation level, press ENTER again to make it effective. At that time the VFD will display ‘**MOD LEVEL=XXdBmV**’ and transmitter will shift back to AGC mode. For instance, if user’s ideal modulating level is **38dBmV**, VFD would display ‘**MOD LEVEL= 38dBmV**’ after operations shown above. Please consult an ATX Networks engineer for help with this feature.  
 At “MGC Status”, press the UP or DOWN button until the VFD displays ‘**MGC ATT=XXdB**’, then press the “Enter” button to select. After selecting, the VFD will display ‘**MGC ATT=XXdBmV**’ and ‘**Please install...**’. At this point the user can change the modulation level in 1dB increments by pressing the UP or DOWN buttons. For instance, the MGC ATT decrease 3dB will increase the MOD LEVEL by 3dB. Once you have selected the desired MGC ATT value, press ENTER again to make it effective.  
**NOTE:** At “AGC Status”, the total RF power to the laser is locked, not depending on the input RF level and channel number. At “MGC Status”, the total RF power to the laser may vary with the input RF level and channel number. The default control mode of the QFOT1310 transmitter is AGC.
- 7 **RF Input Test Port:** Standard 75Ω style F-style test port for RF signal on-line test. Level tested from this port is 20 dB lower than the actual RF drive level to the laser.

#### 6.2. Rear Panel Guide

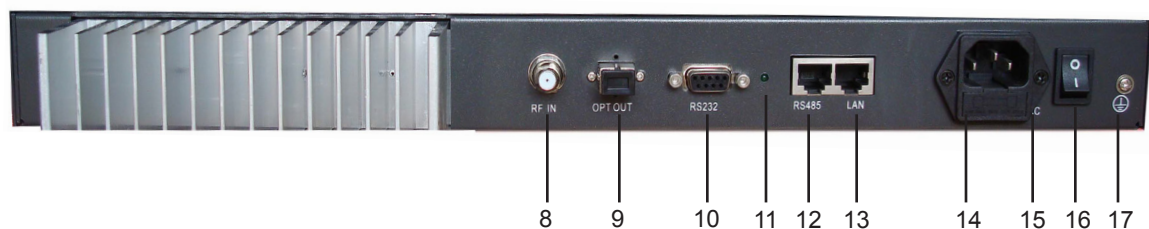

Rear View

- 8 **RF Input Port:** Standard 75Ω American style F port, used for connecting RF signal and the equipment. Level in this input port must be at the range of 15~25 dBmV. Too high level may damage laser. **Optimum input level is 17 dBmV.**  
**\*The input level above 17 dBmV may damage Laser. Please consult factory!**

- 9 **Optical Signal Output:** Optical signal output port, SC/APC, or optional FC/APC connector. There are invisible laser emissions from Fiber output when laser is active!  
\*It would be dangerous to point this port toward the human body especially eyes when equipment is energized!
- 10 **RS-232 Standard Network Management Port (optional):** Use for connecting equipment with RS-232 port in network management server.
- 11 **Network Management Indicator**
- 12 **RS-485 Standard Network Management Port (optional):** Use for connecting equipment with RS-485 port on network management server.
- 13 **LAN Network Management Port:** Use for connecting transmitter with Ethernet-based SNMP network management server. (Contact factory for this option)
- 14 **Power In:** AC power connection.
- 15 **Fuse:** AC fuse
- 16 **AC Power Switch:** Turn ON or turn OFF the power.
- 17 **Case Grounding Nut:** Provided for optionally connecting the transmitter to ground.

## 6.3. Parameter Display

### 6.3.1. Turning On Power Display

When first turning on the power, the VFD will display “Initialize...” for 2 seconds and the buzzer will briefly tweet one time indicating that the transmitter has initialized successfully.

### 6.3.2. Status Display

After the transmitter has been powered ON and initialized, pressing the UP or DOWN button on the front panel will scroll the VFD to display in turn the following:

- 1) “Welcome to ATX”: trademark
- 2) “AGC Status”: press “Enter” will switch to “MGC Status”, second “Enter” will go back to AGC
- 3) “S/N: xxxx-xx-xxxx”: equipment series number
- 4) “MOD LEVEL= XXdBmV”: modulating level value
- 5) “AGC ATT-XXdB”: attenuation value at “AGC Status”
- 6) “INPUT RF=XXdBmV”: RF input level
- 7) “BIAS-XX mA”: bias current of the laser
- 8) “TEMP=XX.X °C”: internal temperature value of the laser
- 9) “POWER=XX.X mW”: output power, unit mW
- 10) “QFOT1310-XX-S”: module name, S indicated built-in SNMP Interface Board

## 6.4. Alarm Indication

Display Message	Alarm Status	System Indication
Warning...!!! Input RF is low	Input RF is too low	• <i>Status indicator</i> red light flashes
Warning... !!! Input RF is high	Input RF is too high	• <i>Status indicator</i> red light flashes

# INSTALLATION & ADJUSTMENT

## 7. Installation & Adjustment

### 7.1. Opening the Cover

- 7.1.1. Inspect the package. If the packaging has been damaged, or shows signs of water damage, please contact the freight company or contact ATX.
- 7.1.2. After unpacking, check the equipment and accessories according to packing list. If there is any question, please contact ATX.
- 7.1.3. If you think equipment has been damaged, please don't turn on the power and avoid worse damage. Please contact ATX.

### 7.2. Supplies & Tools

An optical power meter

A digital multimeter

A Cable TV RF meter or spectrum analyzer

A standard fiber test jumper (FC/APC or SC/APC)

Denatured or 99% pure isopropyl alcohol and lint-free fiber optic cleaning wipes

### 7.3. Installation

- a). Mount the equipment in the rack and ground the case.
- b). Check input voltage using a digital multimeter in accordance with power requirement. Then turn on power.
- c). Check the message on the VFD and the status of the front panel LED indicator. Push the **UP** and **DOWN** button to check each parameter, ensuring that the transmitter is operating normally. (If there is no RF input, the red LED will flash, and the VFD will display “**input RF is low**”.)
- d). Connect standard fiber test cable to the transmitter's optical signal output. Measure the output optical power and confirm that the output optical power is the same as the value displayed on the VFD. (When measuring the optical power, make sure that optical power meter is set for 1310nm wavelength and that fiber test jumper is clean.)
- e). Measure the input RF signal level with a Cable TV meter or a spectrum analyzer, making sure that input RF signal is in the range of 15~25 dBmV (optimum value 17 dBmV). At this time, you can now connect the RF signal to the RF signal input port of the equipment. This time front panel LED turns to green and VFD displays RF input value as “**RF INPUT = XXdBmV**”.

The internal RF power detector is calibrated for 77 analog NTSC channels, so the displayed value may not be correct, depending upon your actual channel plan. It is possible to correct the displayed value to read your measured RF level by pressing the UP or DOWN buttons to scroll the VFD until it displays “**RF LEVEL=XXdBmV**”, and then press ENTER. The VFD will now display “**MOD LEVEL=XXdBmV**” and “**Please install...**”, and the user can now set the RF input level in **1 dBmV** increments by pressing the UP or DOWN buttons. When the displayed value is equal to your tested value, press ENTER to make it effective, and at that time the VFD will display “**RF LEVEL=XXdBmV**”. For instance, if real RF input level is **20 dBmV**, VFD would display “**RF LEVEL= 20dBmV**” after operations shown above.

- f). Re-measure optical output power, make sure that optical output power being normal, remove standard fiber test jumper and optical power meter, connect the equipment to network and end the installation.

This page left intentionally blank.

# SNMP MANAGEMENT

With the built-in SNMP interface board, QFOT1310-S can be viewed by SNMP software via the RJ-45 port at the rear panel.

## 8.1. IP Address

**8.1.1.** The QFOT1310-S transmitter default IP address for SNMP management is “192.168.1.20”. The Ethernet Interface hardware and TCP/IP features are as follows:

- 1) **Interface Type:** RJ45
- 2) **Speed Rate:** 10Mbit/s
- 3) **Default IP Address:** 192.168.1.20
- 4) **Default Mask:** 255.255.255.0
- 5) **Default Gateway:** 192.168.1.1

### 8.1.2. SNMP Agent Network Management System

The standard SNMPv1 agent is provided in the built-in SNMP interface board, which can be accessed by the standard SNMP network management tools. SNMPv2 is optional. The parameters of QFOT1310-S can be read by a SNMP software with management information base (MIB), including RF parameters, power information, temperatures, etc.

## 8.2. Setting Private IP Address

The user can change the QFOT1310-S IP address in the following ways.

### 8.2.1. TELNET Management

QFOT1310-S transmitter supports TELNET management. When QFOT1310-S is connected with a computer via RJ-45, the computer IP address should be next to “192.168.1.20”. After both units are linking well, the user can enter the command line in the DOS window:

“telnet 192.168.1.20”, where the “192.168.1.20” is the default IP address of QFOT1310-S.

After successful connection, the user name and password is required.

The default username: admin

The default password: 12345

Now the prompt window is OK, user can enter different operation command.

Commands	Parameter	Description	Appendix
Exit	/	Exit the management console	
Carrier Return	/	Indicate the command was entered	
Admin	/	This is only valid for username prompt	The device has only one username: admin
12345	/	This is only valid for password prompt	The device has only one password: 12345
Logout	/	Logout the console and login prompt window appear again	
Help	/	Show the help window	
?	/	Same as command “Help”	
Ver	/	Show the version information of device	
Set	IP xxxxxxxx Gateway xxxxxxxx Mask xxxxxxxx	Set IP address Set Gateway address Set Mask	“xxx” is the IP address or mask, they can be like this: 192.168.1.2 255.255.255.0

Commands	Parameter	Description	Appendix
Show	/	Show basic information	
Set	Model "xxxxxxx" Model	Set the Model View the Model	When setting the model, the string must include quotation mark, and the max string length is 12
Set	Location "xxxxxx" Location	Set the location of the device View the location	When setting the location string, the string must include quotation mark, and the max length is 12
Reboot	/	Reboot the device	

- NOTE:**
- All commands will be uppercase, so the lowercase or uppercase in commands are the same.
  - The device only support one TELNET session at the same time.
  - The device will disconnect the TELNET session when it is in idle for 5 minutes
  - The user can close the TELNET session in two manners:
    - 1) Input the "quit" command;
    - 2) Either ctrl-x or ctrl-c is OK to close this session
  - If the TELNET session was closed abnormally, user may wait for 5 minutes to reconnect the device with TELNET

## 8.2.2. Console Management

QFOT1310-S transmitter provides console management with RS232 port. The RS232 interface is:

Item	Value
Interface	RS232
Type	DB9-Female
Rate	9600bps
Data Bit	8
Stop Bit	1
Parity	None
Data Flow Control	None

- NOTE:**
- Open the Hyper Terminal of the computer and set the COM port parameter as above
  - Press Carriage Return 3 times to enter into the user and password prompt window
  - Input the username "admin" and password "12345"
  - All commands listed in 7.2.1 are accepted

## 8.2.3. Parameters in SNMP

SNMP software with transmitter MIB can read the parameters from QFOT1310-S. The following are examples of parameters without loading transmitter MIB.

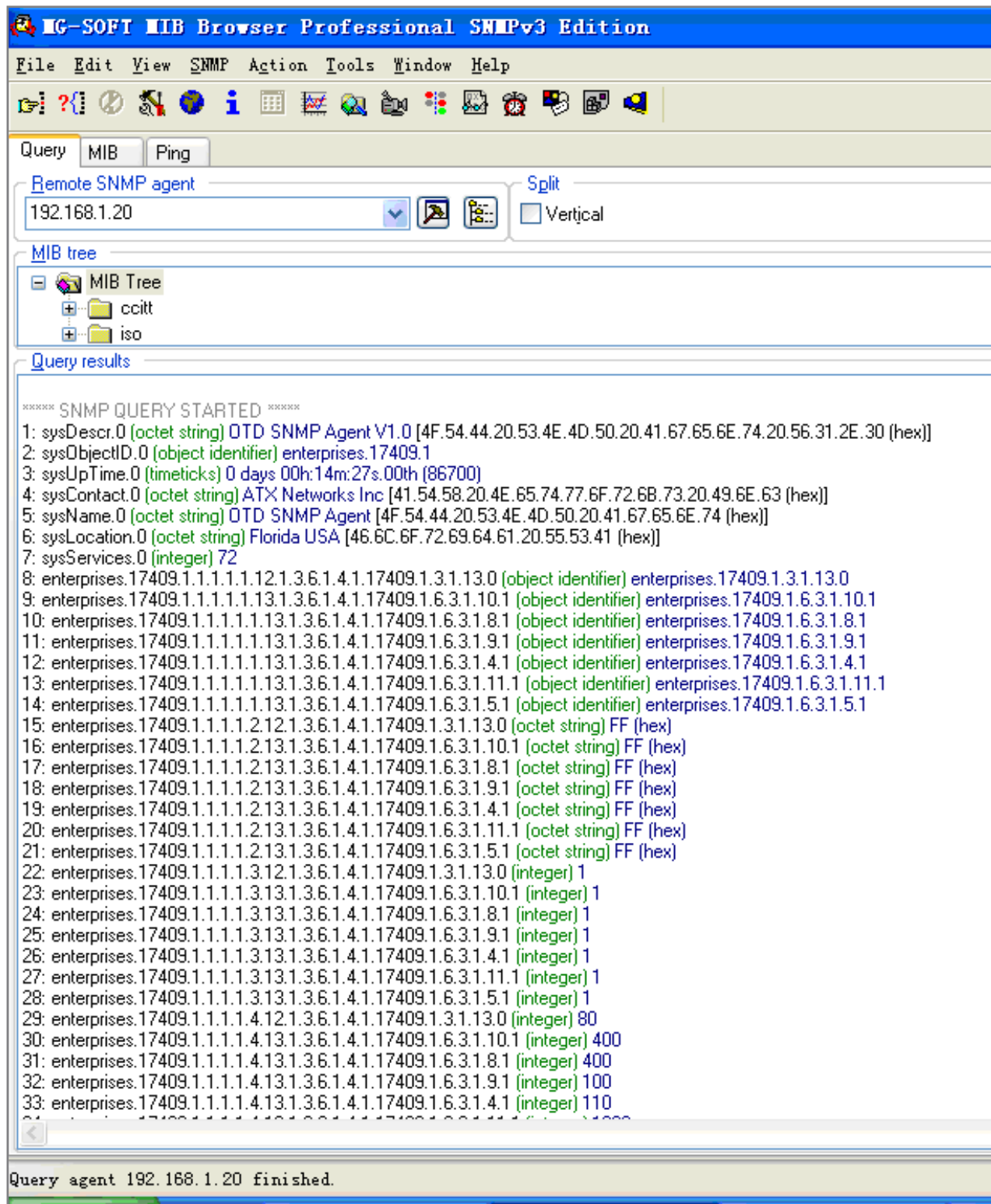

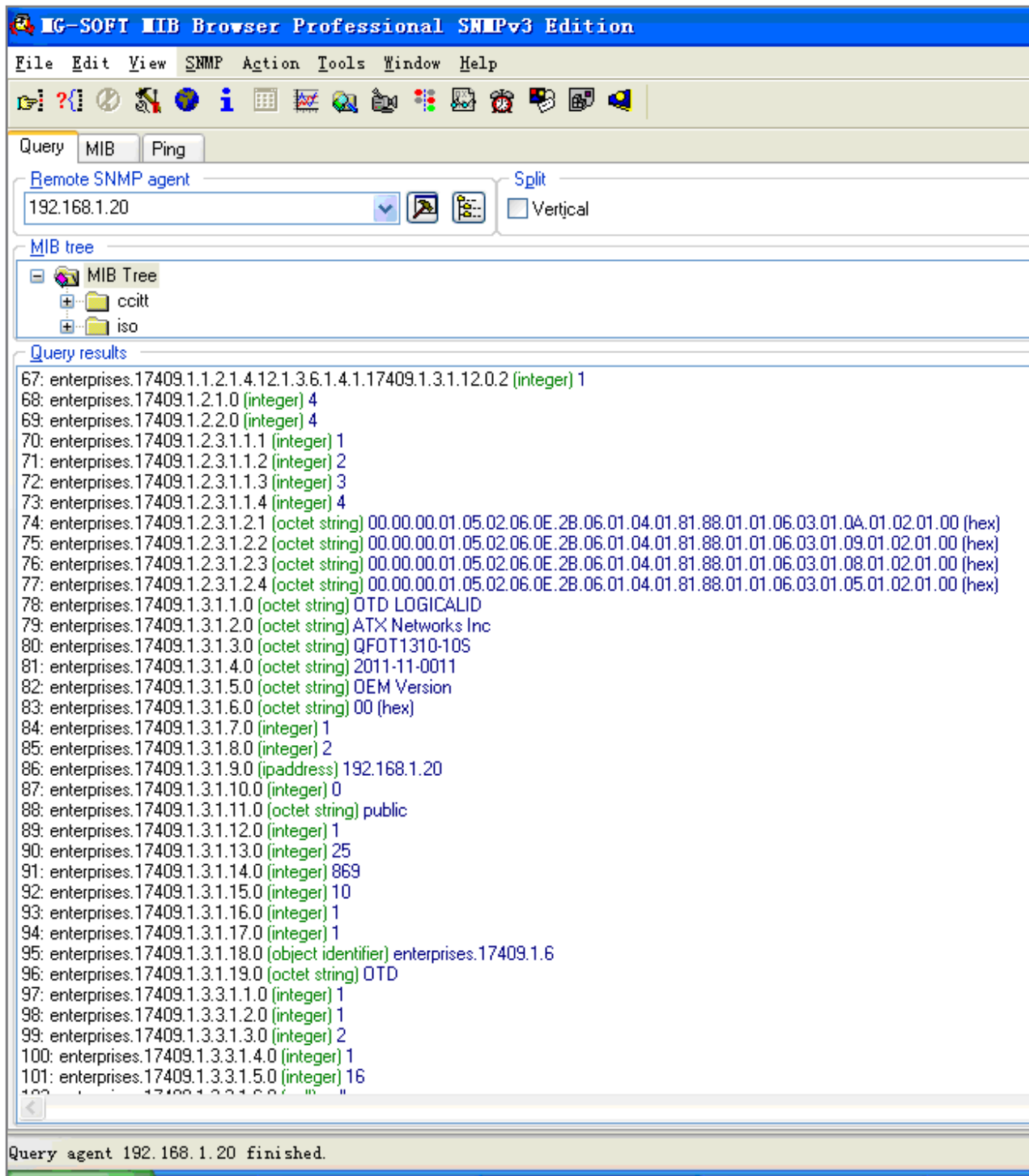

## CLEANING & MAINTENANCE

### 9. Cleaning & Maintenance

Each fiber connector can become contaminated by dust or dirt in the operation process, which can result in increased optical link loss, or a degraded carrier-to-noise ratio. If you find that the optical receiver power or RF output level of the optical receiver has declined, you should clean and maintain the fiber active connector. The cleaning methods are recommended below:

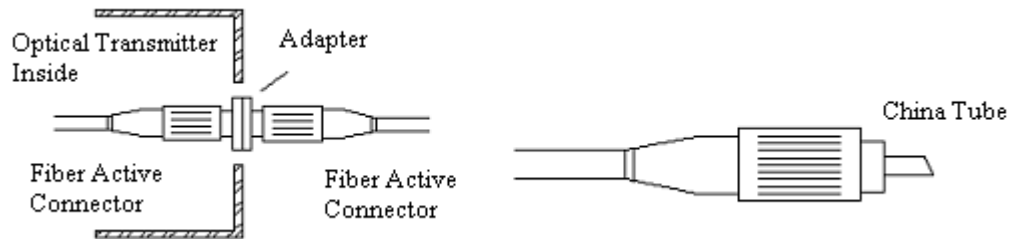

- Carefully unplug or unscrew the active fiber connector from the adapter, while being careful to avoid aiming the fiber connector at any human body or eye.
- Use a lint-free fiber optic wipe saturated with alcohol to clean the connector carefully. Once finished, still wait 1-2 minutes until active connector surface is dry in the air.
- When the cleaned optical active connector is reconnected to the adapter, please do not over-tighten or force the connector, to avoid damage to the ceramic ferrule.
- The fiber active connector should be cleaned on both ends. If optical power is still low after cleaning, clean the other end of the fiber. If the optical power is still low after cleaning both ends, it is recommended that you clean the inner adaptor. (Take care of the fiber when disassembling the adaptor).
- Use compressed air or a lint-free wipe to wash the adapter carefully. When using compressed air, aim the nozzle at the ceramic ferrule of the adaptor to clean.

**NOTE:**

- Avoid aiming the optical output or fiber connector at the human body or eyes.
- Assemble the fiber adaptor gently and carefully to prevent damage to the ceramic ferrule inside the adaptor.

This page left intentionally blank.

## AFTER-SALE CUSTOMER SERVICE

### 10. After-sale Customer Service

- a) Our promises: One year free trouble fixing service and life-long customer service (1 year free guarantee time starts from the date indicated in products S/N attached on side of products).
- b) If the equipment fails, please contact ATX immediately.
- c) Don't try to repair the problem without help from an ATX technician.
- d) **NOTE:** There are adhesive tape seals on both sides of the case. Any unauthorized removal of this tape seal by the user will void the 1 year warranty.

This page left intentionally blank.

# TROUBLESHOOTING

## 11. Troubleshooting

SYMPTOM	FAULT	ACTION
No VFD or LED display after turning on the power.	No input power or a problem with the internal switching power supply.	Check input AC voltage to the power supply (AC90V~250V), if the voltage is normal, usually the cause is the internal switching power supply, contact ATX.
After turning on power, VFD monitor and LED normal, but optical output power low.	<ol style="list-style-type: none"> <li>1. Check jumper quality.</li> <li>2. Contaminated optical active connector or adapter.</li> <li>3. Damaged ceramic ferrule in adapter.</li> </ol>	<ol style="list-style-type: none"> <li>1. Swap to a good test jumper.</li> <li>2. Clean contaminated fiber active connector or adapter.</li> <li>3. Swap the damaged adapter.</li> </ol>
After connecting to network, all TV channels have obvious noise point.	<ol style="list-style-type: none"> <li>1. Low received optical power, causing poor C/N.</li> <li>2. RF input level too low for sufficient laser modulation.</li> <li>3. System link path C/N too low.</li> <li>4. Back-reflection from bad or dirty optical connectors.</li> </ol>	<ol style="list-style-type: none"> <li>1. Clean fiber active connector or adapter (Chapter 9 Cleaning &amp; Maintenance).</li> <li>2. Check RF input levels to transmitter (15-25 dBmV).</li> <li>3. Check link loss.</li> <li>4. Use only angled (SC/APC) optical connectors or fusion splice where necessary.</li> </ol>
After connecting to network, only some TV channels have a degraded SNR.	Some channels SNR too low.	<p>Check the individual channel signal C/N or SNR.</p> <p>Check the flatness of the RF input signal.</p>
After connecting to network, some TV channels have obvious ripple, beats, lines, or distortions.	<ol style="list-style-type: none"> <li>1. Optical input power to receiver too high.</li> <li>2. RF modulation too high.</li> <li>3. RF input drive to transmitter too high.</li> </ol>	<ol style="list-style-type: none"> <li>1. Check input power at optical receiver and pad if necessary.</li> <li>2. Check optical transmitter modulation level parameter, and readjust if too high.</li> <li>3. Make sure the RF input level is within the range (15~25 dBmV).</li> </ol>

Addendum note: to reset the transmitter to the default settings, as shipped from the factory, follow the following steps:

1. Power unit OFF.
2. While holding in both the UP and DOWN buttons, power the unit ON.
3. The VFD will display "Test Mode", and the transmitter will emit a loud beeping noise.
4. Power the unit OFF for 5 seconds, and then back ON. The modulation and display settings have now been restored to the factory defaults. These settings will work for 99% of the applications, and it is rarely needed to deviate from these. Please consult the factory if unsure.

This page left intentionally blank.

## SERVICE & SUPPORT

### 12. Service & Support

#### 12.1. Contact ATX Networks

Please contact ATX Technical Support for assistance with any ATX products. Please contact ATX Customer Service to obtain a valid RMA number for any ATX products that require service and are in or out-of-warranty before returning a failed module to the factory.

ATX Networks  
1-501 Clements Road West  
Ajax, ON L1S 7H4 Canada

Tel: (905) 428-6068  
Toll Free: (800) 565-7488  
Fax: (905) 427-1964  
Toll Free Fax: (866) 427-1964  
Web: [www.atxnetworks.com](http://www.atxnetworks.com)  
E-mail: [support@atxnetworks.com](mailto:support@atxnetworks.com)

#### 12.2. Warranty Information

All of ATX Networks' products have a 1-year warranty that covers manufacturer's defects or failures.



1-501 Clements Road West, Ajax, ON L1S 7H4 Canada  
Tel +1 (905) 428-6068 Toll Free +1 (800) 565-7488 Fax +1 (905) 427-1964 Toll Free Fax +1 (866) 427-1964  
[www.atxnetworks.com](http://www.atxnetworks.com) [support@atxnetworks.com](mailto:support@atxnetworks.com)