

HFC Enhance® LLRX-200 DFB RETURN PATH TRANSMITTER

1. Overview

Figure #1 illustrates the HERX2**** DFB-based Return Path Transmitters.

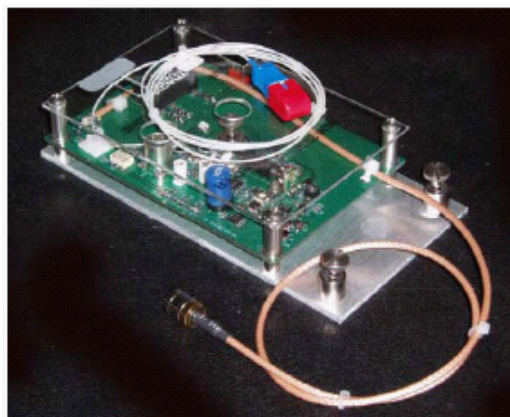

Figure #1 HERX2**** Return Path Transmitter

2. Installation

1. Power off the LLRX Node.
2. Open the LLRX Node; locate the existing return transmitter module in the optical section of the node. The return path transmitter is located between the receiver and the power supply. Remove it and replace it with the new HERX2**** Return Path Transmitter provided. Secure the return path transmitter by tightening the captive screws located on the module.
3. Remove the dust cover from the return path transmitter's optical fiber and connect the fiber to the bulkhead adapter located in the node. Dress the fiber inside the node to prevent it being damaged or pinched when the node is closed. **(NOTE: Always clean the fiber connectors to prevent contamination. Also ensure that the fiber connectors are of the same type, mismatching fiber connectors can cause low signal level or damage to the fiber connector faces).**
4. The RF input connection to the return path transmitter is made by a coaxial cable which is located on top of the module. Route the coaxial cable from the transmitter along the power cable and through the plastic clip on the interface board. Plug the cable into the connector labeled "LSR" on the interface board.
5. Power the LLRX Node back on.
6. Optical output power of the HERX2**** Return Path Transmitter can be measured at the 1V/mW Test Point on the transmitter. Laser current of the return path transmitter can be measured at the 1V/50mA Test Point on the transmitter. Be sure to ground the ground lead of the multimeter to a ground in the node when monitoring these test points.
7. RF input level into the return path transmitter can be measured at the -20 dB Test Point on the transmitter.
8. When everything is connected and the unit is powered, adjust the level of the transmitter for optimum RF drive level (see Section #3).

3. Setting Laser Drive Levels

The HFC Enhance Return Path Transmitters for the LLRX-200 Nodes have been optimized based on the assumption that they will be driven with 37 MHz of loading⁽¹⁾. The optimum drive level (using 6 carriers) at node ports is +24 dBmV⁽¹⁾ per carrier, with 0 dB reverse pads installed. **(NOTE: this translates to an optimum input drive level to the transmitter of +4 dBmV as measured at the -20 dB test point on the transmitter).** Please note that node port 1 can be configured as either an RF input or output.

9. The Return Path can be optimized by injecting a carrier at the node port of level “EXPECTED RETURN CARRIER LEVEL” into the node port (expected level is a system specific design specification) and adjust padding until +4 dBmV is measured on the -20 dB RF test point on the return path transmitter. Figure #2 below provides an overview of the pad locations in the LLRX-200 node. **(NOTE: the return transmitter has a factory installed OMI pad. The OMI pad value should never be changed. Changing the OMI pad value in the field can cause undesirable performance).**
10. Repeat steps 7 to 9 for all remaining ports as necessary.

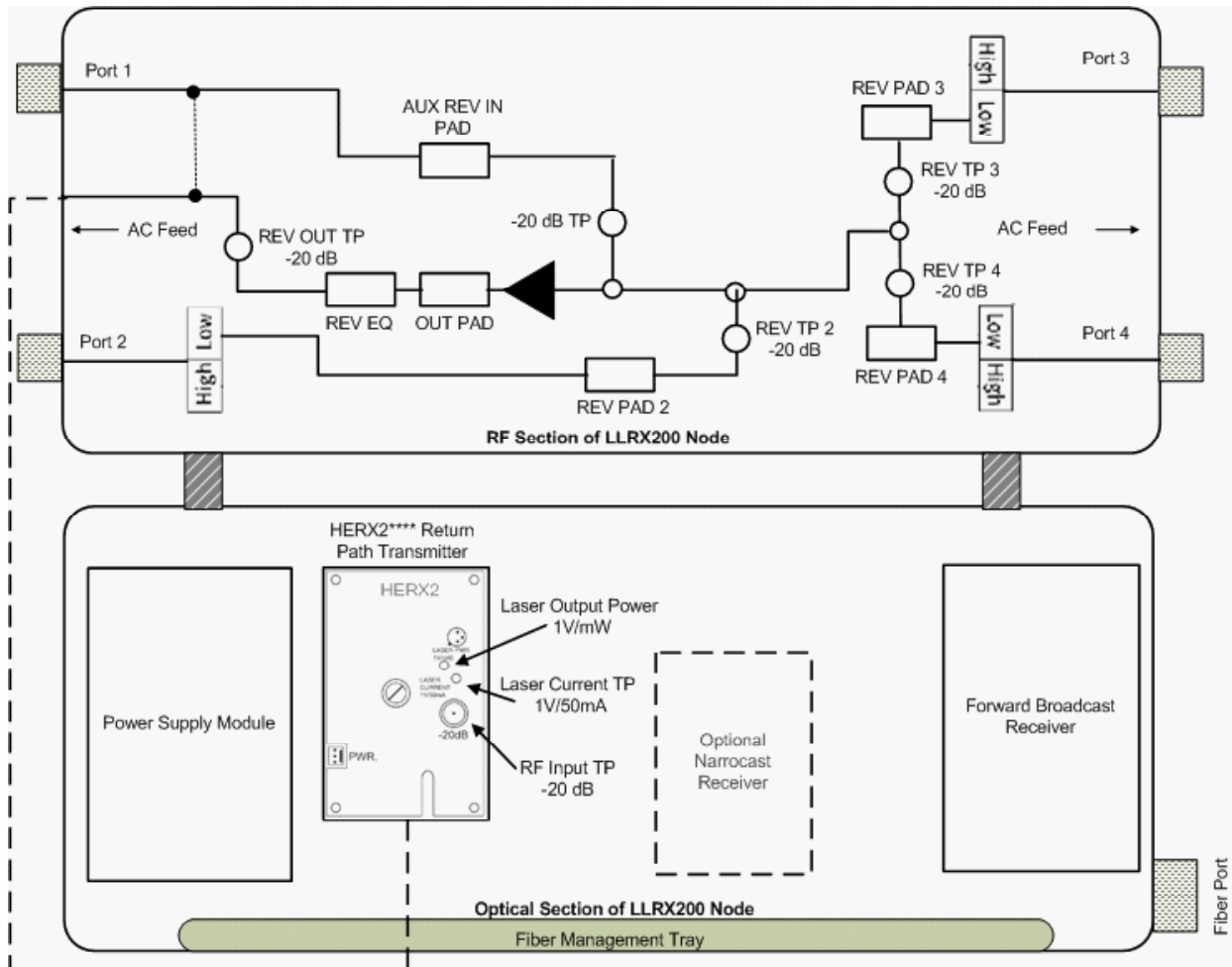

Figure #2 LLRX-200 Node Overview

(1) The optimum operating point for the transmitter is selected as the point that is 5 dB above the location where the noise side of the NPR curve crosses 41 dB. The NPR curve is generated using 37 MHz of noise loading and the per carrier power level is calculated assuming that the total power is calculated at the optimum operating point is spread across 6 carriers. Hence, the optimum drive level of +4 dBmV for the HERX2**** assumes a total of 6 carriers of loading.



Service & Support

Contact ATX Networks

Please contact ATX Technical Support for assistance with any ATX products. Please contact ATX Customer Service to obtain a valid RMA number for any ATX products that require service and are in or out-of-warranty before returning a failed module to the factory.

ATX Networks
1-501 Clements Road West
Ajax, ON L1S 7H4 Canada

Tel: (905) 428-6068
Toll Free: (800) 565-7488
Fax: (905) 427-1964
Toll Free Fax: (866) 427-1964
Web: www.atxnetworks.com
E-mail: support@atxnetworks.com

Warranty Information

All of ATX Networks' products have a 1-year warranty that covers manufacturer's defects or failures.



1-501 Clements Road West, Ajax, ON L1S 7H4 Canada
Tel +1 (905) 428-6068 Toll Free +1 (800) 565-7488 Fax +1 (905) 427-1964 Toll Free Fax +1 (866) 427-1964
www.atxnetworks.com support@atxnetworks.com