



---

**MAXNET® II**

*Platinum Series*

Pat.# U.S. 7,142,414

**QMP200**

**Return RF/IF Amplifier Manual**



# TABLE OF CONTENTS

	<b>Page</b>
<b>1. PRODUCT DESCRIPTION .....</b>	<b>1-1</b>
1.1. Functional Diagram .....	1-2
1.2. Technical Specifications .....	1-2
<b>2. INSTALLATION .....</b>	<b>2-1</b>
2.1. Product Inspection .....	2-1
2.2. Module Installation into the Active MAXNET® II Chassis .....	2-1
2.3. RF Connections .....	2-1
2.4. Amplifier Set-Up .....	2-2
<b>3. STATUS MONITORING .....</b>	<b>3-1</b>
3.1. Chassis Interface Options .....	3-1
3.2. SCTE HMS MIB Software Definition of Module .....	3-1
3.3. Web Interface .....	3-1
3.4. Updating Active Chassis Firmware .....	3-2
3.5. Factory Reset .....	3-2
<b>4. STATUS MONITORING FEATURES .....</b>	<b>4-1</b>
4.1. SNMP Parameters .....	4-1
4.2. SNMP MIBs Required .....	4-2
<b>5. MAINTENANCE &amp; TROUBLESHOOTING .....</b>	<b>5-1</b>
5.1. Maintenance .....	5-1
5.2. Troubleshooting .....	5-1
<b>6. SERVICE &amp; SUPPORT .....</b>	<b>6-1</b>
6.1. Contact ATX Networks .....	6-1
6.2. Warranty Information .....	6-1
6.3. Safety .....	6-1

# Index of Figures and Tables

## **Figures**

#1 Return RF/IF Amplifier Functional Diagram .....	1-2
#2 Front & Rear Panel Pictures .....	2-1
#3 Front Panel Plug-ins .....	2-2

## **Tables**

#1 Ordering Information .....	1-1
#2 Technical Specifications .....	1-2
#3 LED Status Indications .....	2-2
#4 Plug-in PAD/EQ Specifications .....	2-3
#5 Plug-in PAD/EQ Ordering Information .....	2-3
#6 Common Module SNMP Parameters .....	4-1
#7 QMP200 SNMP Parameters .....	4-1
#8 General SCTE HMS MIBs Required .....	4-2
#9 QMP200 SCTE HMS MIBs Required .....	4-2

# PRODUCT DESCRIPTION

## 1. Product Description

The QMP200 MAXNET II modules are Return RF/IF Amplifiers, which offer two gain versions (20 dB and 28 dB) that are determined at the time of ordering. The QMP200 amplifier is a single stage amplifier as shown in the functional diagram. The QMP200 amplifiers are dual-width, taking up two slots in the Active MAXNET II Chassis and they are powered through a hot-swapping backplane in the Active MAXNET II Chassis. An appropriate MAXNET II Power Supply in the Active MAXNET II Chassis powers these modules. The QMP200 modules feature the standard MAXNET II functionality including high-density packaging through the use of MCX coaxial cable connectors in conjunction with Mini RG-59 Type coaxial cable. Also featured are: front access alarm LED indicator, -20 dB test points and the capability of module status monitoring through SNMP based Managers. The MAXNET II SNMP interface is HMS compliant.

Please refer to the web page for up-to-date specifications – [www.atxnetworks.com](http://www.atxnetworks.com)

Part Number	Description
QMP200-28L	200 MHz, 28 dB Gain Single Stage, MCX Connectors
QMP200-20L	200 MHz, 20 dB Gain Single Stage, MCX Connectors
QMP200-28LF	200 MHz, 28 dB Gain Single Stage, F Connectors
QMP200-20LF	200 MHz, 20 dB Gain Single Stage, F Connectors

**Table #1: Ordering Information**

## 1.1. Functional Diagram

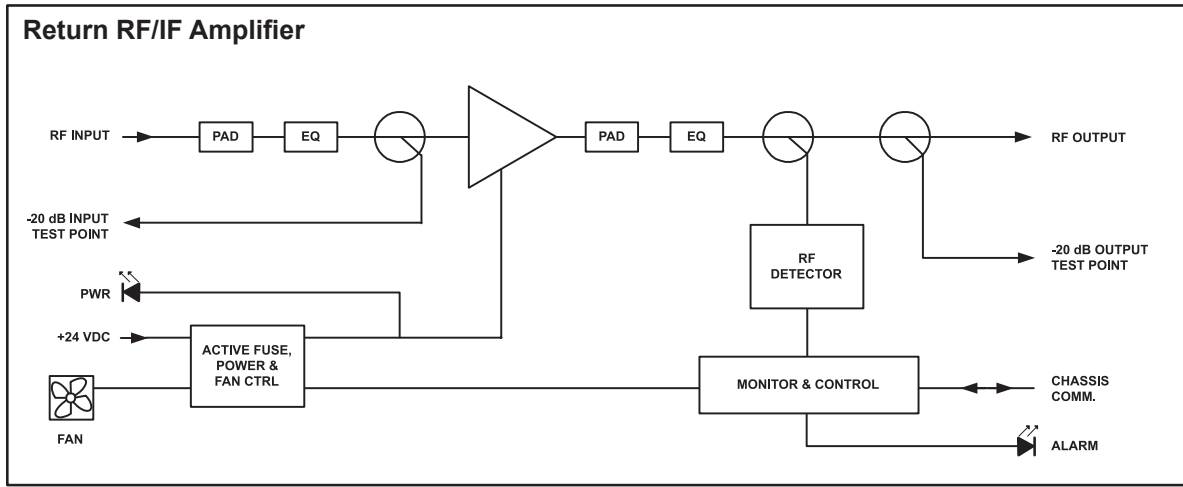

Figure #1: Return RF/IF Amplifier Functional Diagram

## 1.2. Technical Specifications

PART NUMBER (3)	GAIN		GAIN AND SLOPE CONTROL (1)	TEST POINTS (4)	RETURN LOSS	DISTORTION PERFORMANCE					NOISE FIGURE	OPERATING CURRENT (2)
	BW (MHz)	GAIN (dB)	PLUG-IN	I/O (dB)	I/O (dB)	OUTPUT LEVEL (dBmV)	CH. LOAD (#)	CH. SLOPE (dB)	CTB (-dB)	CSO (-dB)	(dB)	(mA)
QMP200-28L	5-200	28 +/- 1.0	INPUT / OUTPUT	20 +/- 1.0	18	50	10	0	74	65	7	140
QMP200-20L	5-200	20 +/- 1.0	INPUT / OUTPUT	20 +/- 1.0	18	50	10	0	75	65	7	140
QMP200-28LF	5-200	28 +/- 1.0	INPUT / OUTPUT	20 +/- 1.0	18	50	10	0	74	65	7	140
QMP200-20LF	5-200	20 +/- 1.0	INPUT / OUTPUT	20 +/- 1.0	18	50	10	0	75	65	7	140

**NOTES:**

- See functional schematics.
- DC load current at + 24 VDC.
- L = MCX connectors; LF = F connectors.
- At input test point specified with 0 dB plug-in attenuator and 0 dB plug-in EQ.

Table #2: Technical Specifications

# INSTALLATION

## 2. Installation

### 2.1. Product Inspection

Carefully unpack the amplifier module from the shipping box. If the box or amplifier module is damaged, please notify the freight company to make a damage claim. If you suspect that there is a problem with the amplifier module that may affect its safe operation, do not install such a suspect Amplifier into the Active MAXNET II Chassis.

### 2.2. Module Installation into the Active MAXNET® II Chassis

Slide the dual-width QMP200 amplifier module into an open slot in the Active MAXNET II Chassis, one that spans two single-width module locations beginning with an odd number (indicated by a white marker on the chassis), until the module drops into its lock position. **The module must be inserted into an odd number slot in order for the amplifier module to properly mate to the active chassis back plane.** If the module is installed properly, the amplifier will make contact with the 24 VDC power bus in the chassis and if there is a MAXNET II Power Supply Module installed in the chassis, and it is plugged into the respective power source, the module's PWR (Power) LED indicator will light green. To remove an amplifier module from the chassis, gently lift the front handle and pull back on the module until it is clear of the chassis guide slot.

Initially, when inserted in the Active MAXNET II Chassis, the amplifier will start alarming (the front panel ALM (Alarm) LED indicator will start flashing red), as there is no RF input signal. The amplifier will stop alarming once RF signal is applied to the input and all other parameters are within operating conditions.



Figure #2: Front & Rear Panel Pictures  
Shown with MCX (left) and F (right) Rear Panel Connectors

### 2.3. RF Connections

The RF jacks on the QMP200 amplifiers front/rear panel are MCX [female]. As an option, the RF jacks on the rear panel can be F type [female]. There will be one RF input and one RF output at the rear, plus two front panel 20 dB test points per QMP200 amplifier. The output (OUT) test point is  $-20$  dB relative to the RF output. The input (IN) test point is  $-20$  dB relative to the RF input, if input PAD and EQ are 0 dB (see Functional Diagram). The RF Input connector on the rear panel is the top connector and the RF Output connector on the rear panel is the bottom connector. Connect a test jumper from output or test point ports to a signal level meter or spectrum analyzer to verify signal quality and adjust RF levels before connecting subsequent equipment.

The operator can adjust the RF level by inserting PAD's and EQ's as shown in the Functional Diagram (Figure 1).

## 2.4. Amplifier Set-up

### 2.4.1. Amplifier LED Indicators

The MAXNET II QMP200 Amplifiers have two LED indicators: PWR and ALM.

- a) The PWR (Power) LED verifies that the amplifier module is receiving power from the MAXNET II Power Supply through the 24 VDC Chassis Bus. The PWR LED is always solid green when the module is powered. If no powering is available then the PWR LED is off. The PWR LED does not have a flashing condition.
- b) The ALM LED will FLASH RED if there is a problem with the amplifier or if any of its monitored functions are beyond the specified limits (e.g. absence of RF input signal).

		STATUS		
		FLASHING RED <sup>1</sup>	SOLID GREEN	OFF
LED	PWR	N/A	Power ON	Check Power Supply
	ALM	Alarm	N/A	Normal

Table #3: LED Status Indications

### 2.4.2. Amplifier Front Panel Controls (Padding & Equalizer)

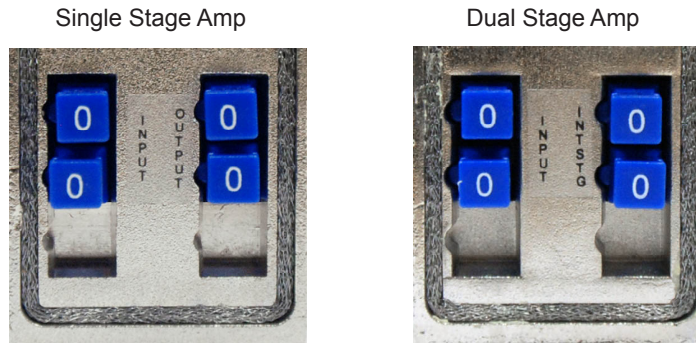

Figure #3: Front Panel Plug-in's

The QMP200 Amplifier plug-in padding and plug-in equalizer are accessible by removing the front cover. Remove the access cover from the front of the QMP200 Amplifier module by turning the thumbscrew counter-clockwise. This will expose two blocks of two PAD's/EQ's. The ones on the left side are connected to the RF Input and the ones on the right side are connected to the RF Output.

<sup>1</sup> If the ALM LED is flashing red at a slow rate of approximately 1s on-1s off, this is indicative of a communications failure between this module and the chassis. See Troubleshooting section.

dB VALUES	FREQ. RANGE	IMPEDANCE	RETURN LOSS	TILT	FLATNESS
0 dB	5 - 1000 MHz	75 ohm	≥ 20 dB	N/A	N/A
1-20 dB	5 - 1000 MHz	75 ohm	≥ 20 dB	≤ 0.5 dB	+/- 0.2 dB

EQ VALUES	SLOPE 1000/45 MHz	INSERTION LOSS	EQUALIZER TOLERANCE	RETURN LOSS	IMPEDANCE
1.5 dB	1.4 dB	≤ 1 dB	+/- 0.5 dB	≥ 18 dB	75 ohm
3 dB	3.2 dB				
4.5 dB	3.8 dB				
6 dB	5.1 dB				
7.5 dB	6.2 dB				
9 dB	7.1 dB				
10.5 dB	8.7 dB				

Table #4: Plug-in PAD/EQ Specifications

Part Number	Description
MP*PAD	Plug-in Pad (* = dB value, 0 to 20 dB) (must order in quantities of 10)
MP*EQ	Plug-in Equalizer, 1000 MHz (* = dB value, 1.5 to 10.5 dB) (must order in quantities of 10)

Table #5: Plug-in PAD/EQ Ordering Information

This page left intentionally blank.

# STATUS MONITORING

## 3. Status Monitoring

### 3.1. Chassis Interface Options

The Active MAXNET II product line can be monitored and controlled in either of two ways:

- A free, web-based interface. This comes pre-installed on every chassis and provides a user friendly method of configuring the administrative setup and all monitoring and control. It is based on SNMP, but requires little knowledge of SNMP. Any internet browser, such as Internet Explorer, is all the software that is required.
- Any third-party SNMP Management software (e.g. [www.castlerock.com](http://www.castlerock.com), [www.ndt-inc.com/SNMP/MIBrowser.html](http://www.ndt-inc.com/SNMP/MIBrowser.html)) may be purchased separately. These suites tend to be expensive and not as user friendly as the web interface. The web interface is also still required for administrative setup. The 3rd party interface is recommended only for systems that have an existing SNMP architecture. All MIBs (Management Information Bases) are freely downloadable from the SCTE ([www.scte.org/standards](http://www.scte.org/standards)). ATX was able to support all modules using the SCTE standard HMS MIBs, so no custom MIBs are required.

### 3.2. SCTE HMS MIB Software Definition of Module

The headend RF Amp MIB is used to provide only an Output RF detector value, allowing HI and LO alarm thresholds to be set.

### 3.3. Web Interface

The MAXNET II chassis uses an integrated web page to supplement the SNMP management. All configuration of the chassis (static IP address, trap/email recipients, firmware upgrades, etc) must be done through the web page. Simply use any web browser (Internet Explorer, Firefox, etc) and enter the IP address of the chassis as the URL. Login as administrator to modify configuration and have full read/write access to monitor and control modules. Login as Operator to have full read/write access or login as observer to have read-only access. There is only one password per login level.

The screenshot shows the MAXNET II web interface. The top navigation bar includes 'Status', 'Configuration', and 'Logout'. Below this, there are tabs for 'Overview', 'Chassis', 'Software Status', and 'Accessory'. The main content area is titled 'Parameters' and includes sub-tabs for 'Analog' and 'Discrete'. A 'Save Changes' button is located at the bottom of the page.

Parameter	Value	Properties
Model	QMP200-34GP	
Description	Reverse Amp with RF Det, 200MHz	
Name	Module in Slot 7	
Alias	<input type="text"/>	
Manufacturer	ATX	
Asset ID	<input type="text"/>	
Serial Number	8A-00-00-00-1F-3D-CD-22	
Hardware Rev	2.4	
Firmware Rev	2.1	
Temperature [C]	37.0	<a href="#">Analog</a>
Alarm Detection Control	<input type="text" value="detectionEnabled"/>	
Voltage In [V]	23.2	<a href="#">Analog</a>
Current In [mA]	539	<a href="#">Analog</a>
Power In [W]	12.50	<a href="#">Analog</a>
Fan Unit Status	normal	<a href="#">Discrete</a>
RF Amp Output Description	34.0 dB Gain Output	
RF Amp Output Level [dBmV]	46.2	<a href="#">Analog</a>

### 3.4. Updating Active Chassis Firmware

- a) Login to web page interface of the chassis as an administrator.
- b) Check software status page for current rev level. If an upgrade is necessary, proceed with next steps.
- c) Go to Firmware tab.
- d) Select 'HTTP Server' and verify it reads:  
[www.atxnetworks.com/firmware/MN2/image.bin](http://www.atxnetworks.com/firmware/MN2/image.bin)
- e) Select Upload and wait for confirmation page to appear. The chassis will perform an MD5 checksum on the downloaded file to verify that no bit errors occurred.
- f) If you are updating a version prior to 1.4.2, then the calculated MD5 Checksum will be displayed on the screen. Contact Engineering at ATX to verify what this value should be (it will be the same for each chassis you upgrade with a given revision).
- g) If you are updating a chassis later than 1.4.2, then the checksum is verified automatically via a text file taken from the ATX web server.
- h) If md5checksum is verified, select Flash to memory. **Do not flash if it fails the MD5 checksum**, as this could permanently corrupt the memory.
- i) Wait approximately 5 seconds, then disconnect the network cable and proceed to the next chassis. **Leave the recently updated chassis powered** until it completes a reboot.
- j) Optionally, the chassis may now be factory reset to restore all IP settings to factory defaults. Read the factory reset section fully before doing this to know what data will be lost when doing this.

### 3.5. Factory Reset

A factory reset will restore the chassis to the state which it left the ATX production facility.

#### 3.5.1. Parameters that will be Changed

IP address = 192.168.0.1

Net Mask = 255.255.255.0

Gateway = 192.168.0.254

Passwords set to same text (but all lower case) as the login level. e.g. Operator password is operator.

All analogue and discrete alarm thresholds of modules will be reset to default values.

Alarm log will be cleared.

#### 3.5.2. Purpose

Common reasons for requiring a factory reset are:

- a) The chassis is unresponsive, or the IP address is not known
- b) The Administrator password has been forgotten
- c) The yellow COMM LED does not blink after the 2 minute boot cycle, even after a power cycle or press of the RESET button.

#### 3.5.3. Method

If you are sure you want to factory reset, hold down the RESET button near the RJ45 port for at least 10 seconds. The yellow COMM LED will be solid-on during this time, and once it turns off you can release the button and the reboot process will begin.

# STATUS MONITORING FEATURES

## 4. Status Monitoring Features

### 4.1. SNMP Parameters

Display Name	Description	HMS MIB Variable
Model	ATX model number (note, in empty slots you can enter passive, dual-passive, or empty to populate the overview page with passive picture placeholders).	entPhysicalModelName
Description	Description of the module.	entPhysicalDescr
Name	Indicates the slot of the chassis the module is in.	entPhysicalName
Alias	Optional user defined field - added to fifth variable binding of traps and emails e.g. set this to "Node 69" for a given Receiver and any alarms generated by this receiver will have "Node 69" in the description. Otherwise, it would only contain the IP address of the chassis, the Model and Name (slot number).	entPhysicalAlias
Manufacturer	ATX	entPhysicalMfgName
Asset I.D	Optional user settable field (suggestions: enter in a custom serial number or purchase order # for tracking).	entPhysicalAssetID
Serial No	Module's serial number.	entPhysicalSerialNum
Hardware Rev	Hardware rev of module.	entPhysicalHardwareRev
Firmware Rev	Firmware rev of module.	entPhysicalFirmwareRev
Temperature [C]	Module's current heatsink temperature.	heCommonTemperature
Alarm Detection Control	detectionEnabled: normal operation, with active alarms detectionDisabled: used to temporarily disable alarms/traps from this module detectionEnabledandRegenerate: enter detectionEnabled state while regenerating all alarm table entries	heCommonAlarmDetectionControl
Fan Unit Status	Alarm status of the fan.	heFanUnitAlarm

Table #6: Common Module SNMP Parameters

Display Name	Description	HMS MIB Variable
Voltage In [Volt]	Measured voltage supplied to the module from the chassis (nominally 24V).	hePsUnitVoltageIN
Current In [mA]	Current taken from the 24V rail by the module.	hePsUnitCurrentIN
Power In [Watts]	P.S. Voltage * P.S. Current	hePsUnitPowerIN
RF Amp Output Description	Description of the approx gain value of the amp.	heRFampOutputDescription
RF Amp Output Level [dBmV]	Composite RF level at output of amp.	heRFampOutputLevel

Table #7: QMP200 SNMP Parameters

## 4.2. SNMP MIBs Required

	<b>HMS#</b>	<b>SCTE#</b>
SCTE-ROOT	028	36
SCTE-HMS-ROOTS	072	37
SCTE-HMS-HEADENDIDENT-MIB	114	38-11
SCTE-HMS-HE-COMMON-MIB	111	84-1
SCTE-HMS-PROPERTY-MIB	026	38-1
SCTE-HMS-HE-FAN-MIB	117	84-3
SCTE-HMS-HE-POWER-SUPPLY-MIB	116	84-2

**Table #8: General SCTE HMS MIBs Required**

	<b>HMS#</b>	<b>SCTE#</b>
SCTE-HMS-HE-RF-MIB	133	83-4
SCTE-HMS-HE-RF-AMP-MIB	131	94-1

**Table #9: QMP200 SCTE HMS MIB's Required**

# MAINTENANCE & TROUBLESHOOTING

## 5. Maintenance & Troubleshooting

### 5.1. Maintenance

Daily, ensure that the Power LED's are on for all of the modules and that there are no Alarm lights. Ensure that the yellow 'COM' LED near the rear RJ45 port is blinking.

Weekly, ensure that all module cooling fans are operational and unobstructed.

Monthly, vacuum all module cooling fans.

### 5.2. Troubleshooting

The following guide will help the operator to diagnose problems in active modules or chassis'. If none of the items in this section are of help, please contact ATX for Technical Support.

#### 5.2.1. Slow Flashing Red LED on Module Front

If any alarm LED on the front of the module is blinking at a rate of approximately 1 second ON, 1 second OFF, then this is indicative of a slot addressing communications failure. RF and Optical functionality will likely still work, but the unit will have no software monitoring or control during this time.

Try removing the module and replacing it. If this does not fix the problem, then switch the module to a different slot in the chassis. If the red LEDs return to normal operation, then the problem is in actual slot of the chassis and likely the connector on the back rail is damaged. Contact ATX and report a defective chassis.

If this does not fix the problem then contact ATX and report a defective module.

#### 5.2.2. Chassis' Yellow COM LED Not Blinking

It is normal for the round LED near the RJ45 port at the rear of the chassis to be solid ON or OFF during various states of system boot-up. If the chassis has been powered up (solid green on the round "+24V" LED near the terminal block at the rear of the chassis) for at least 2 minutes, then the yellow LED should be blinking to indicate the chassis software is running. If it is not, a reboot is necessary.

If the chassis can be interrupted briefly, then simply remove power to it by pulling all MPAC/MPDC modules out part-way.

If the chassis must remain live then try pressing the black RESET button near the RJ45 port. If this does not work, then the communications module itself can be removed from the back of the chassis. Remove the two phillips screws that hold the module on, then pull it off and replace it. This will not interrupt the operation of the modules within the chassis.

If this still does not start the yellow LED blinking after boot-up, then a factory reset will be necessary. See Section 3.5.

#### 5.2.3. No Response from Chassis Over Network

Typically, this is a 'subnet' issue. In order for any device to see another device on the same network, they must be on the same subnet. Consult your IT department for details of your network, but typically the subnet refers to the first three of the four octets in an IP address. E.g. if the computers in your network are given IP addresses of 192.168.10.1 through 192.168.10.250, then the subnet is the 192.168.10 part.

Each MAXNET II chassis ships with a default IP of 192.168.0.1, so the PC connected to it must have an IP address of 192.168.0.x where x is not equal to 1. This is not generally the case, so it must be forced.

To modify the PC's IP in Windows, choose Start -> Settings -> Network Connections -> Local Area Connection -> Properties -> Internet Protocol (TCP/IP).

If the chassis IP is no longer at the default IP, modify the subnet portions of these settings (IP address and Default Gateway) to match.

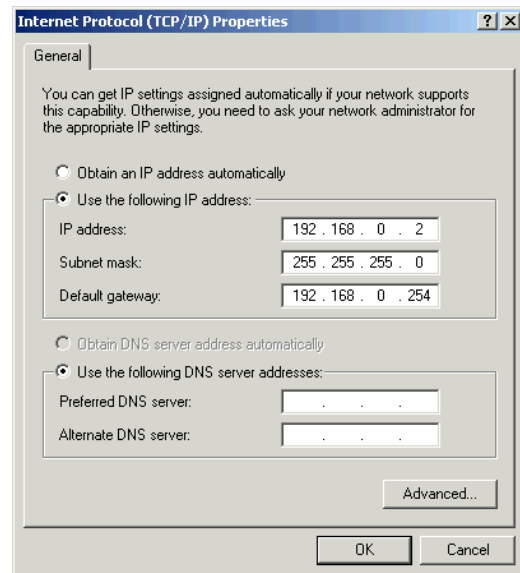

If the chassis is still not visible, it is possible the IP address of the chassis has been forgotten (see Factory Reset section), the network connection is not good (see Ethernet Port section for LED diagnostics) or a network port is blocked or firewalled (check with your IT department).

#### 5.2.4. Some Modules Do Not Show Up On Web Page

If the chassis is visible on the web or through SNMP walks, but one or more installed modules is not, try removing and replacing the module in a different slot. Verify that the green power LED is solid and the red LED is either off or blinking quickly (approx half second on, half second off). If the LED's are not as stated, see the appropriate troubleshooting section.

#### 5.2.5. Module Power LED Off or Intermittent

Check the '24V' green LED on the rear of the chassis. If it is off, then the problem is that the chassis is not getting power. See MPAC/MPDC troubleshooting section. If it is on or if other modules in the chassis are okay, the module itself is suspect. Continue.

Remove the suspect module and trade slot positions with another functioning module.

- If the suspect module is okay and the previously good module fails, contact ATX and report a defective chassis.
- If the suspect module fails and the previously good module is okay, contact ATX and report that the suspect module is defective.

#### 5.2.6. MPAC/MPDC Not Powering Chassis

\*Note that 220 VAC applied to an MPAC-110 will damage the module, but 110 VAC applied to an MPAC-220 will simply not turn on.

- Check the fuse continuity on the MPAC or MPDC module.
- Verify that the 110 VAC / 220 VAC electrical outlet is active using a voltmeter and checking the circuit breaker. (In the case of the MPDC insure that there is -48 VDC on the rear terminal block).
- Verify that IEC power cord is properly inserted into the receptacle on the rear of the module and properly connected to a 110 VAC / 220 VAC electrical outlet.

#### 5.2.7. Module Will Not Insert Fully into Chassis

- Remove the module and inspect it for damage or bent guide rails.
- Inspect the chassis for bent metal or obstructions.

- c) Be sure that the active module is inserted such that the left side is above an odd numbered slot and the right side is above an even number slot.
- d) Try the module in a different slot. Due to machinery tolerances, some modules may be more snug in some slots than others. If the tolerances are unacceptable, contact ATX.

### 5.2.8. Temperature/Fan Fault Alarm on any MAXNET® II Active Module

Check to see if the module fan is operating. If not replace with a new fan from ATX (Fan Part #: MPFANA) using the below procedure.



1. Remove two screws holding plate and fan in place.

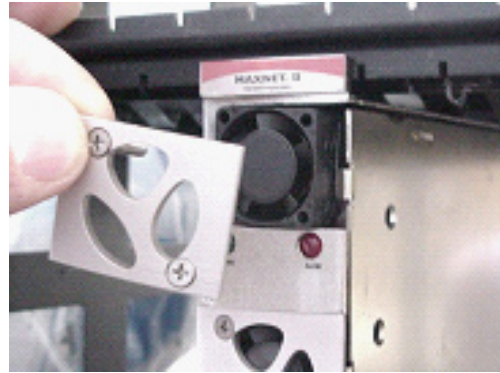

2. Remove fan cover and screws.



3. Pull out fan with tweezers.

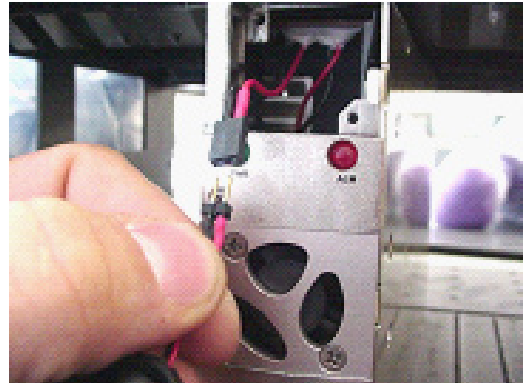

4. Remove push-fit power connections.

5. Install replacement fan in the opposite order shown. Ensuring that:
  - a) The red and black wires are aligned.
  - b) The labelled side of the fan faces inward toward the module.
  - c) The wires do not bunch up behind the fan, interfering with fan rotation.

This page left intentionally blank.

## SERVICE & SUPPORT

### 6. Service & Support

#### 6.1. Contact ATX Networks

Please contact ATX Technical Support for assistance with any ATX products. Please contact ATX Customer Service to obtain a valid RMA number for any ATX products that require service and are in or out-of-warranty before returning a failed module to the factory.

ATX Networks  
1-501 Clements Road West  
Ajax, ON L1S 7H4 Canada

Tel: (905) 428-6068  
Toll Free: (800) 565-7488  
Fax: (905) 427-1964  
Toll Free Fax: (866) 427-1964  
Web: [www.atxnetworks.com](http://www.atxnetworks.com)  
E-mail: [support@atxnetworks.com](mailto:support@atxnetworks.com)

#### 6.2. Warranty Information

All of ATX Networks' products have a 1-year warranty that covers manufacturer's defects or failures.

#### 6.3. Safety

**IMPORTANT! FOR YOUR PROTECTION, PLEASE READ THE FOLLOWING:**

**WATER AND MOISTURE:** Care should be taken so that objects do not fall and liquids are not spilled into the enclosure through openings.

**POWER SOURCES:** The device should be connected to a power supply only of the type described in the operating instructions or as marked on the device.

**GROUNDING OR POLARIZATION:** Precautions should be taken so that the grounding or polarization means of the device is not defeated.

**POWER CORD PROTECTION:** Power supply cords should be routed so that they are not likely to be pinched by items placed upon or against them, paying particular attention to cords at plugs, convenience receptacles, and the point where they exit from the device.

**SERVICING:** The user should not attempt to service the device beyond that described in the operating instructions. All other servicing should be referred to qualified service personnel.

**FUSING:** If your device is equipped with a fused receptacle, replace only with the same type fuse. Refer to replacement text on the unit for correct fuse type.



1-501 Clements Road West, Ajax, ON L1S 7H4 Canada  
Tel +1 (905) 428-6068 Toll Free +1 (800) 565-7488 Fax +1 (905) 427-1964 Toll Free Fax +1 (866) 427-1964  
[www.atxnetworks.com](http://www.atxnetworks.com) [support@atxnetworks.com](mailto:support@atxnetworks.com)