

Arris/Antec LLRX200 Single Return Path Transmitter:

Features & Benefits:

- ▶ 1310nm, 1550nm or CWDM, DFB-based return path transmitter module
- ▶ Designed to perform better than or equal to the original manufacturer's model
- ▶ Replace failed legacy return path transmitters or improve return path performance by replacing existing F-P transmitter module with a DFB transmitter module
- ▶ Single transmitter modules allow for immediate legacy module replacement or upgrade
- ▶ Convenient test point for RF input level. DC test points provides indicator of optical output power (1V/mW) & laser current (1V/50mA)
- ▶ Low power consumption & good heat dissipation increases service life & reliability

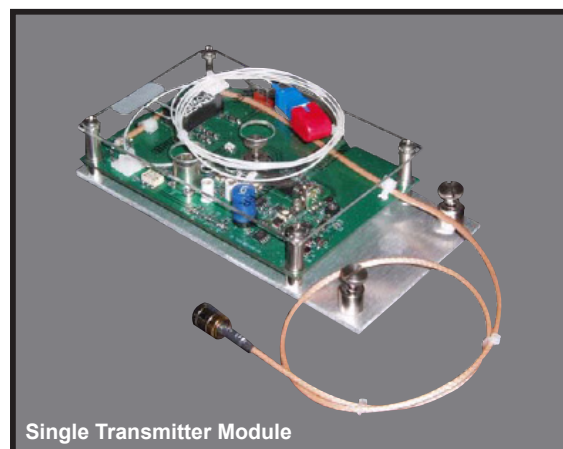

LLRX200 Return Path Transmitter Specifications

SPECIFICATIONS		RETURN TRANSMITTERS: DFB & CWDM
RF INPUT & PERFORMANCE PARAMETERS		
FREQUENCY RESPONSE RANGE (+/- 1.0 dB)	5-220 MHz	
NPR (DFB/CWDM)*	> 15 dB over 41 dB NPR*	
INPUT RETURN LOSS	> 16 dB	
OPTICAL OUTPUT PARAMETERS		
OPTICAL OUTPUT (DFB)	1.0, 2.0 or 3.0mW @ 1310nm / 2.5mW @ 1550nm CWDM	
RETURN LOSS	> 60 dB with APC Connectors	
OPTICAL CONNECTORS	SC/APC; FC/APC; SC/UPC; FC/UPC	
USER INTERFACE		
OPTICAL OUTPUT LEVEL	1V/mW	
LASER CURRENT	1V/50mA	
RF INPUT LEVEL	-20 dB	
ELECTRICAL, ENVIRONMENTAL & MECHANICAL PARAMETERS		
OPERATING TEMPERATURE	-40°C to +70°C (-40°F to +158°F) (temperature at mounting plate)	
HUMIDITY	20%-55% (without condensation, inside housing)	
POWERING	Single Transmitter Module: 24 VDC/50mA	
PHYSICAL		
DIMENSIONS	1.14"H x 6.22"W x 3.15"D (2.9H x 15.8W x 8.0D cm)	
WEIGHT	0.5 lbs (0.22 kg)	
NOTES:		
* Measured with 10 dB of fiber & 6 channel, 37 MHz loading, with +11 dBmV per channel RF input. Call ATX for assistance in determining optimum drive levels for your system.		

Arris/Antec LLRX200 Single Return Path Transmitter:

Ordering Information

Return Path Transmitter Modules:

<p>1310nm DFB</p> <p>HERX213</p> <ul style="list-style-type: none"> 1 = 1mW 2 = 2mW 3 = 3mW <p>SA = SC/APC SU = SC/UPC FA = FC/APC FU = FC/UPC</p>	<p>1550nm and CWDM DFB, 2.5mW</p> <p>HERX_ 2.5</p> <ul style="list-style-type: none"> SA = SC/APC SU = SC/UPC FA = FC/APC FU = FC/UPC <p>15 = 1550nm 47 = 1470nm 49 = 1490nm 51 = 1510nm 53 = 1530nm</p>
---	---

Functional Schematic

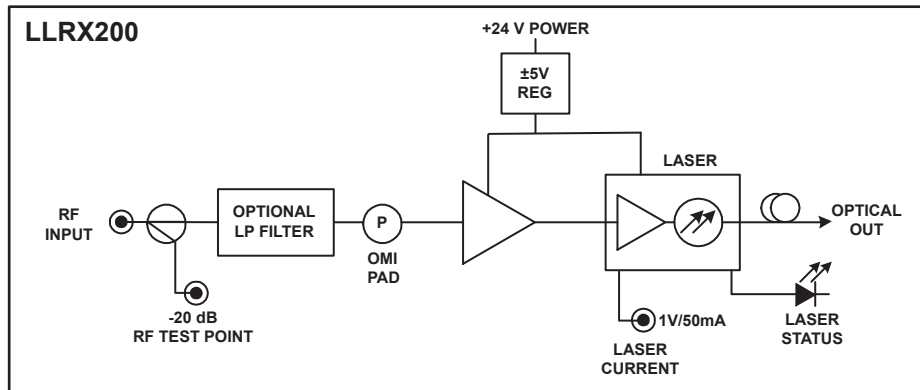

HFC Enhance® is a registered trademark of ATX in the United States and/or other countries. Products or features contained herein may be covered by one or more U.S. or foreign patents. Arris/Antec and other non-ATX product and company names mentioned in this data sheet are the property of their respective companies.



Specifications subject to change without notice.