

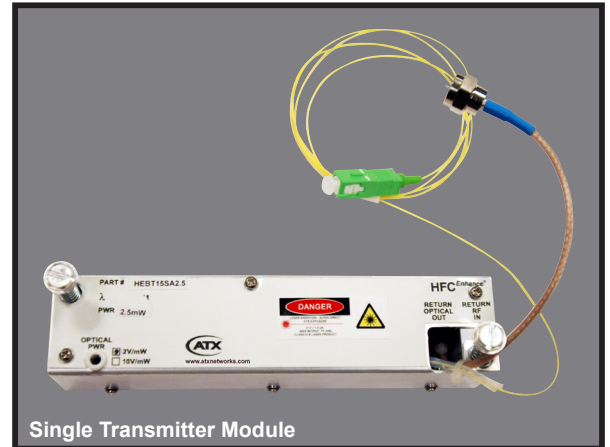

BTN Single Return Path Transmitters:

Features & Benefits:

- ▶ 1310nm, 1550nm or CWDM, DFB-based return path transmitter module
- ▶ Replace failed legacy return path transmitters or improve return path performance by replacing existing F-P transmitter module with a DFB transmitter module
- ▶ Single transmitter modules allow for immediate legacy module replacement or upgrade
- ▶ Target CW carrier level (indicated on the transmitter) allows technician to easily set the drive level to the transmitter for optimized performance
- ▶ Convenient DC test point provides indicator of optical output power (1V/mW)
- ▶ Low power consumption & good heat dissipation increases service life & reliability



BTN Return Path Transmitter Specifications

SPECIFICATIONS		RETURN TRANSMITTERS: DFB & CWDM
RF INPUT & PERFORMANCE PARAMETERS		
FREQUENCY RESPONSE RANGE (+/- 1.0 dB)	5-220 MHz	
NPR (DFB/CWDM)*	> 15 dB over 41 dB NPR*	
INPUT RETURN LOSS	> 16 dB	
OPTICAL OUTPUT PARAMETERS		
OPTICAL OUTPUT (DFB)	1.0, 2.0 or 3.0mW @ 1310nm / 2.5mW @ 1550nm CWDM	
RETURN LOSS	> 60 dB with APC Connector	
OPTICAL CONNECTOR	SC/APC; FC/APC; SC/UPC; FC/UPC	
USER INTERFACE		
OPTICAL OUTPUT LEVEL	1V/mW	
LASER ON INDICATOR	LED	
ELECTRICAL, ENVIRONMENTAL & MECHANICAL PARAMETERS		
OPERATING TEMPERATURE	-40°C to +60°C (-40°F to +140°F) (ambient temperature around Node)	
HUMIDITY	20%-55% (without condensation, inside housing)	
POWERING	Single Transmitter Module: 24V, 65mA	
PHYSICAL		
DIMENSIONS	1.97"H x 5.59"W x 1.34"D (5.0H x 14.2W x 3.4D cm)	
WEIGHT	0.5 lbs (0.23 kg)	
NOTES:		
* Measured with 17 km of fiber, 35 MHz loading. Call ATX for assistance in determining optimum drive levels for your system.		

BTN Single Return Path Transmitters:

Ordering Information

Single Transmitter Modules:	
<p>1310nm DFB</p> <p>HEBT13</p> <ul style="list-style-type: none"> 1 = 1mW 2 = 2mW 3 = 3mW <ul style="list-style-type: none"> SA = SC/APC SU = SC/UPC FA = FC/APC FU = FC/UPC 	<p>1550nm and CWDM DFB, 2.5mW</p> <p>HEBT 2.5</p> <ul style="list-style-type: none"> SA = SC/APC SU = SC/UPC FA = FC/APC FU = FC/UPC <ul style="list-style-type: none"> 15 = 1550nm 47 = 1470nm 49 = 1490nm 51 = 1510nm 53 = 1530nm

Functional Schematic

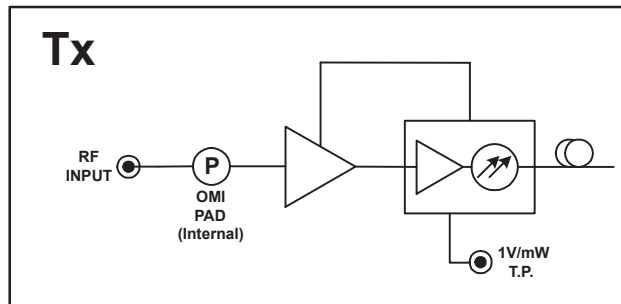

HFC Enhance® is a registered trademark of ATX in the United States and/or other countries. Products or features contained herein may be covered by one or more U.S. or foreign patents. BTN and other non-ATX product and company names mentioned in this data sheet are the property of their respective companies.



Specifications subject to change without notice.