



MAXNET® II

Platinum Series

Pat.# U.S. 7,142,414

MP3

Active / Passive Chassis Manual

TABLE OF CONTENTS

	Page
1. PRODUCT DESCRIPTION	1-1
1.1. Functional Diagrams.....	1-2
1.2. Technical Specifications	1-2
2. INSTALLATION	2-1
2.1. Module Installation Into the MP3 Chassis	2-1
2.2. Powering the Active MP3 Chassis.....	2-1
2.3. Remote Chassis Power Applications.....	2-2
2.4. Module Power Requirements	2-3
3. HARDWARE NETWORK SET-UP.....	3-1
3.1. LED Indicators	3-1
3.2. Ethernet Port	3-1
4. STATUS MONITORING	4-1
4.1. Chassis Interface Options	4-1
4.2. Software Network Set-up.....	4-1
4.3. Web Interface	4-1
4.4. Module Replacement.....	4-2
4.5. Updating Active Chassis Firmware.....	4-2
4.6. Factory Reset	4-2
4.7. SNMP Parameters.....	4-3
4.8. SNMP MIBs Required	4-7
5. MAINTENANCE & TROUBLESHOOTING.....	5-1
5.1. Maintenance.....	5-1
5.2. Troubleshooting.....	5-1
6. SERVICE & SUPPORT.....	6-1
6.1. Contact ATX Networks.....	6-1
6.2. Warranty Information	6-1
6.3. Safety	6-1

Index of Figures and Tables

Figures

#1 Active Chassis Functional Diagram	1-2
#2 Remote Powering	2-3
#3 Redundant Powering	2-3
#4 Redundant Remote Powering	2-3

Tables

#1 Ordering Information	1-1
#2 Active Chassis Technical Specifications	1-2
#3 Terminal Block Pin Assignments	2-2
#4 Ethernet Interface Pin Assignments	3-2
#5 Ethernet Interface LED Indicators	3-2
#6 Administration Level SNMP Parameters	4-3
#7 Common Module SNMP Parameters	4-4
#8 RF and Optical Switch SNMP Parameters	4-5
#9 MPTX Laser SNMP Parameters	4-6
#10 Misc. SNMP Parameters	4-6
#11 General IETF MIBs Required - All Modules	4-7
#12 General SCTE HMS MIBs Required - All Modules	4-7
#13 Module-Specific SCTE HMS MIB's Required	4-7

PRODUCT DESCRIPTION

1. Product Description

The MP3 chassis is a 3RU design that comes in both a passive and active configuration. Both configurations include options for dual cable management bars and a large cable management tray as well as user configurable horizontal and vertical cable management systems. The MP3 active chassis also include a fiber management tray that can be configured into two positions.

The passive and active chassis' can accommodate up to 24 single-width passive modules (DC Logic A/B RF Switch; 2, 4, 8, dual 4-way and triple 2-way splitters/combiners; DC & triple DCs) or up to 12 dual-width modules (16-way splitter/combiners).

The active chassis can accommodate all the modules that a passive chassis can, but also up to 12 dual-width active modules (amplifier, power supply, optical receiver/transmitter, RF Switch).

The active chassis comes with a +24 VDC power interface backplane/rail and a removable communications module that draws power from the rail. This communications module can be removed without affecting the operation of the modules in the chassis by removing the two Phillips screws on either side that fasten it to the chassis. All active modules are hot-swappable. Power is supplied to the backplane by installing an MPAC or MPDC power supply into one of the chassis slots or by remotely powering the chassis from an external 24 VDC supply. The MP3 active chassis is equipped with an HMS compliant SNMP management system. An RJ-45 port is used for both set-up and status monitoring. No custom software is required.

Please refer to the web page for up-to-date specifications – www.atxnetworks.com

Part Number	Description
MP1	1RU Passive Chassis with Cable Management Bar
MP3B	3RU Passive Chassis with Dual Cable Management Cable Bars
MP3H	3RU Passive Chassis with Configurable Horizontal Channel Cable Management
MP3V	3RU Passive Chassis with Configurable Vertical Channel Cable Management
MP3T	3RU Passive Chassis with Large Cable Management Tray
MP3R	3RU Passive Reverse Chassis
MP3BA	3RU Active Chassis with Dual Cable Management Cable Bars
MP3HA	3RU Active Chassis with Configurable Horizontal Channel Cable Management
MP3VA	3RU Active Chassis with Configurable Vertical Channel Cable Management
MP3TA	3RU Active Chassis with Large Cable Management Tray
MPFT	Fiber Management Tray (includes 12 push fit plastic fiber guides) for 3RU Chassis
MPLT	Large Cable Management Tray (includes clips)
MP3FA	3RU Active Chassis for F Connector Optics Platform (includes rear rails for patch panels & front fiber tray)
MP3FA-COM	Replacement Communication Module for MP3FA
MP3FA-T	Replacement Fiber Management Tray for MP3FA

Table #1: Ordering Information

(See http://www.atxnetworks.com/pdf/ANW0614_MNII_ChassisCableOptns.pdf for photos of various options)

¹ Provided that the chassis is not being solely powered via the terminal block on the comm module, there would simply be no alarms and no remote adjustment of parameters. The modules would continue to run with the last set values.

² It is not recommended to hot swap a power supply module into a full chassis if there is no other power supply present. The current surge to supply a full rack of active modules would be stressful on the electrical contacts during mating and may reduce the lifespan of the chassis and power supply. It is recommended that you install the power supply first, then apply AC or DC input to the power supply connector.

1.1. Functional Diagrams

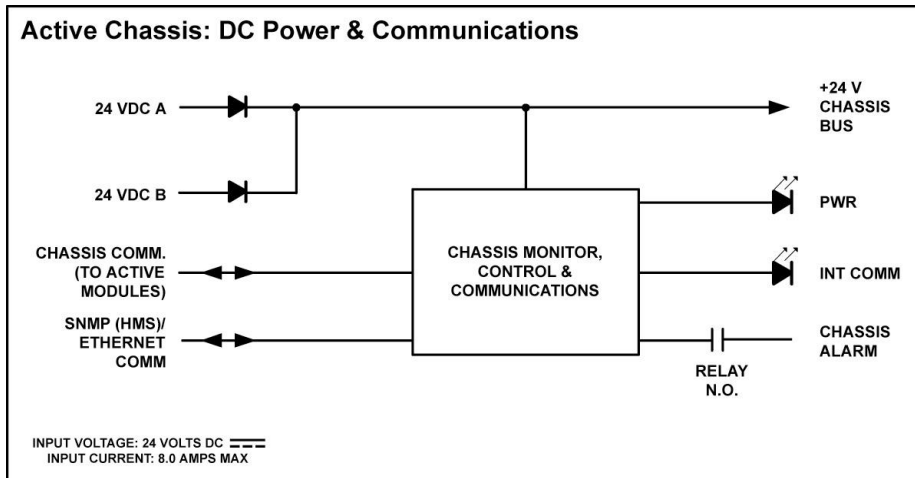

Figure #1: Active Chassis Functional Diagram

1.2. Technical Specifications

ELECTRICAL SPECIFICATIONS	
DC INPUT	
INPUT VOLTAGE	24 VDC
INPUT CURRENT (Max)	8 Amps DC
OTHER	
24V POWER INDICATOR	Green LED
COMMUNICATION STATUS	Yellow LED
TERMINAL BLOCK WIRING	# 12 AWG
COMMUNICATIONS INTERFACE	10/100 Base-T Web / SNMP (HMS)
NOTE: Powering can be provided via A/B input on rear terminal block or by plug-in MPAC/MPDC power supplies.	

Table #2: Active Chassis Technical Specifications

INSTALLATION

2. Installation

The MP3 is a 3RU chassis and comes pre-assembled and ready to mount to any existing 19" rack cabinet hub system using 10/32" rack screws.

NOTE: This equipment is intended for installation in a **RESTRICTED ACCESS LOCATION** only.

NOTE: Not for use in a computer room as defined in the Standard for Protection of Electronic Computer/Data Processing Equipment, ANSI/NFPA 75.

Rack Mounting Precautions

- a) **Elevated Operating Ambient** - If installed in a closed or multi-unit rack assembly, the operating ambient temperature of the rack environment may be greater than room ambient. Therefore, consideration should be given to installing the equipment in an environment compatible with the maximum ambient temperature (35°C) specified by the manufacturer.
- b) **Reduced Air Flow** - Installation of the equipment in a rack should be such that the amount of airflow required for safe operation of the equipment is not compromised.
- c) **Mechanical Loading** - Mounting of the equipment in the rack should be such that a hazardous condition is not achieved due to uneven mechanical loading.
- d) **Circuit Overloading** - Consideration should be given to the connection of the equipment to the supply circuit and the effect that overloading of the circuits might have on overcurrent protection and supply wiring. Appropriate consideration of equipment nameplate ratings should be used when addressing this concern.
- e) **Reliable Earthing** - Reliable earthing of rack-mounted equipment should be maintained. Particular attention should be given to supply connections other than direct connections to the branch circuit (e.g. use of power strips)."

2.1. Module Installation Into the MP3 Chassis





All MAXNET II active and passive chassis have 24 grooves that act as guide slots for the active and passive modules. Passive modules and the DC Logic Switch can be inserted into any of the 24 slots. Active modules **must be inserted into the odd number slots indicated by the white markers on the bottom rail of the chassis**. These odd numbered slots are the only slots that will allow an active module to be connected to the active chassis backplane to receive power and allow monitor and control of the module. To insert a module, align the module guide rails to the chassis guide slots and then gently slide the module into a locked position (the module should be flush against the top and bottom rail of the chassis). No mounting hardware is required. To remove a module, grab the front handle on the module and gently lift and pull back the module until it is clear of the chassis guide rails.

NOTE: When installing the MPAC or MPDC Power Supply, the GND bonding terminal #1 on the back of the MPAC or MPDC Power Supply shall be connected to the chassis ground lug.

2.2. Powering the Active MP3 Chassis

The MP3 active chassis can be powered by power supply modules (MPAC-110, MPAC-220 or MPDC) installed in one of the slots of the chassis, or by connecting power directly to one or both of the terminal block inputs on the rear of the chassis. Both connections are not necessary unless redundancy is required. If the source of 24 VDC is not an MPXX power supply, the line should be fused at a minimum with a 10 Amp slo-blo fuse. A disconnect device is required between the 24 VDC supply and the Chassis remote power terminals.

2.3. Remote Chassis Power Applications

RLY NO	RLY COM	+24V B	COM	+24V A
				

NAME	DESCRIPTION
+ 24V A	+24 VDC input A
COM	Ground
+24V B	+24 VDC input B
RLY COM	Common Relay Contact
RLY NO	Normally Open Relay Contact (fault condition if open circuit to RLY COM)

* recommended minimum of #12 gauge wire rated for up to 10A

Table #3: Terminal Block Pin Assignments

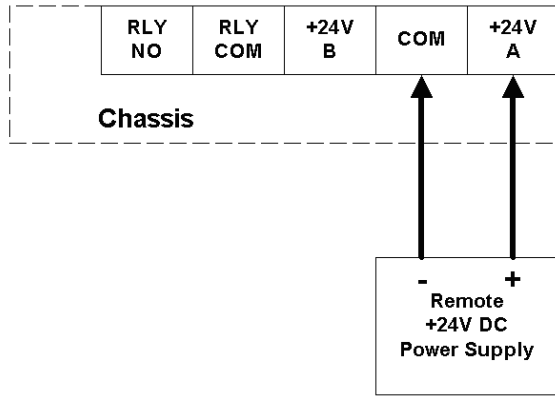

Figure #2: Remote Powering

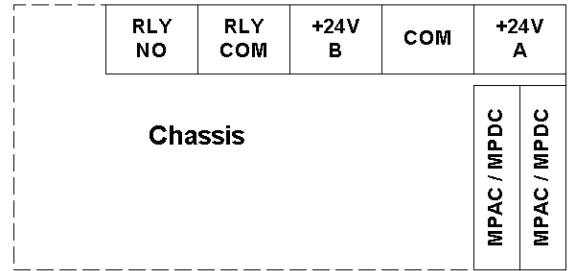

Figure #3: Redundant Powering

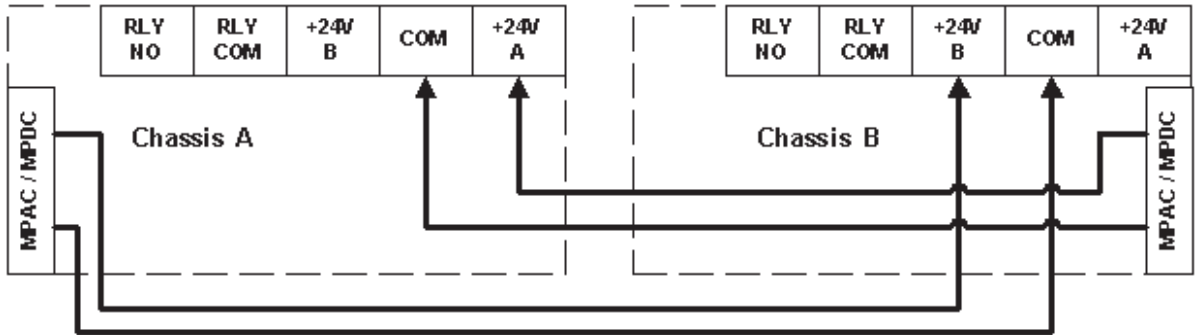

Figure #4: Redundant Remote Powering

* In any of the examples above, be sure to refer to the next section for module power requirements. In any redundant scenario, if a power supply fails, the load on any remaining power supply must not exceed 8 amps.

2.4. Module Power Requirements

Module	MPAC / MPDC	MPRX-8 / MPRX-16	MPRX2-8	MPRXRR-16 / MPRXRR-8	MPRX-DC / MPRX2-DC	MPRX2-DC	MPRFA/B	QMP200	QMP1000 (< 22 dB Gain)	QMP1000 (> 22 dB Gain)
Max Current (A)	8	0.29	0.52	0.46	0.29	0.52	0.03	0.14	0.47	0.52

This page left intentionally blank.

HARDWARE NETWORK SET-UP

3. Hardware Network Set-up

The MP3 active chassis can be easily connected to an existing network through the use of a patch cable connected between the network port on the rear of the chassis and any switch or router. For a connection directly to a PC or laptop, use a crossover cable. This product has been verified to work on Windows XP/2000 and Linux operating systems.

3.1. LED Indicators

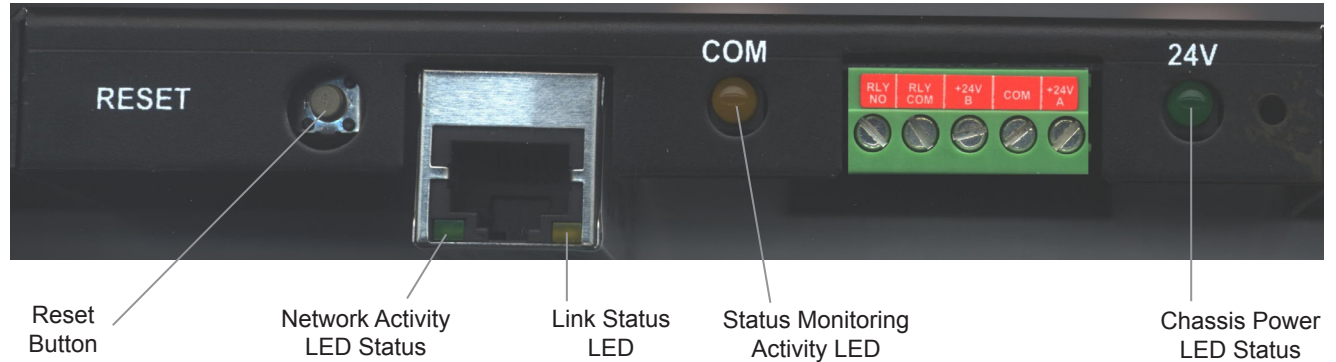

There are four LED's visible at the rear of the chassis. Two small square LEDs on the RJ45 port itself (see the next section for details on these), a large yellow 'COM' and green '24V' LED.

The '24V' LED indicates the presence of power to the chassis and comm module, it should always be solid and bright.

The 'COM' LED will be solid during the boot cycle of the device but should start blinking after approximately 2 minutes. It must always be blinking during regular operation to indicate the monitoring software is running.

3.2. Ethernet Port

The RJ45 Ethernet port visible at the rear of the chassis is actually the DC-ME-01T-C embedded device server, manufactured by Digi International and loaded with custom ATX firmware. The following figures and text were taken directly from the "Digi Connect ME & Digi Connect Wi-ME Hardware Reference". For more information, please go to www.digi.com.

The Ethernet connector is an 8-wire RJ-45 jack that meets the ISO 8877 requirements for 10/100BASE-T. See the following figure and table for pin orientation and pin assignments.

The yellow LED indicates whether a valid network connection is present. It should be solid. Otherwise, check the network cable or the piece of hardware that has been connected to the network cable (switch, router or PC's network card).

The green LED indicates network activity. It will be solid during any boot process (approx 2 min) and then blink if there is any network traffic. If it remains solid, this may be indicative of corrupt hardware – contact ATX Networks.

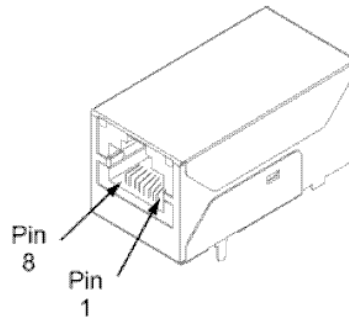

Ethernet Interface Pin Assignments							
Pin 1	Pin 2	Pin 3	Pin 4	Pin 5	Pin 6	Pin 7	Pin 8
TXD+	TXD-	RXD+	EPWR+	EPWR+	RXD-	EPWR-	EPWR-
Transmit Data +	Transmit Data -	Receive Data +	Power from Switch +	Power from Switch +	Receive Data -	Power from Switch -	Power from Switch -

Table #4: Ethernet Interface Pin Assignments

LED	Pin Header EM	Integration Kit Digi Connect ME
Top left (yellow)	5 (+) 7 (-)	Network link status: Off - no link has been detected. On - a link has been detected.
Top right (green)	1 (+) 3 (-)	Serial port activity/Network activity: Off - the serial channel is idle. Blinking - serial data is transmitted or received.

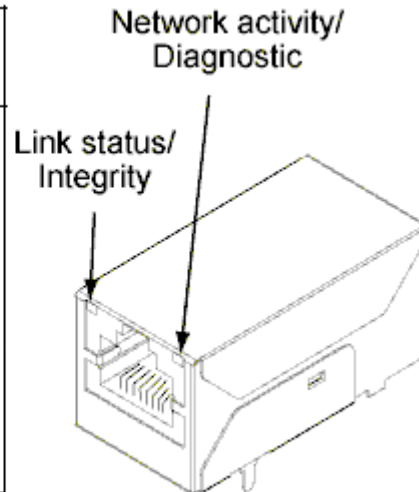

Table #5: Ethernet Interface LED Indicators

STATUS MONITORING

4. Status Monitoring

4.1. Chassis Interface Options

The Active MAXNET II product line can be monitored and controlled in either of two ways:

- a) A free, web-based interface. This comes pre-installed on every chassis and provides a user friendly method of configuring the administrative set-up and all monitoring and control. It is based on SNMP, but requires little knowledge of SNMP. Any Internet browser, such as Internet Explorer, is all the software that is required.
- b) Any third-party SNMP Management software (eg. www.castlerock.com, www.ndt-inc.com/SNMP/MIBrowser.html) may be purchased separately. These suites tend to be expensive and not as user friendly as the web interface. The web interface is also still required for administrative set-up. The 3rd party interface is recommended only for systems that have an existing SNMP architecture. All MIBs (Management Information Bases) are freely downloadable from the SCTE (www.scte.org/standards). ATX was able to support all modules using the SCTE standard HMS MIBs, so no custom MIBs are required.

4.2. Software Network Set-up

- a) Recommended: Connect the chassis to a PC/laptop directly with a cross-over network cable.
Alternative: Connect the chassis to a switch or router using a patch network cable.
- b) Enter the IP address of the chassis as the URL in a web browser. By default (factory reset), this will be 192.168.0.1. If the device does not respond, see Troubleshooting section at the end of this document.
- c) The login page should appear. Login as administrator (default password for all levels is the lower case name of the level, i.e. Observer password is observer).
- d) The configuration settings page should appear. It is important to either use DHCP or (preferably) assign a unique IP address to each MP3 chassis that will be on the same subnet as your DHCP server assigns addresses. "Same Subnet" refers to an IP address that has the same first three octets, but a unique fourth octet e.g. 192.168.0.1 and 192.168.0.2 are on the same subnet.
- e) Obtain a list of IP addresses from your IT department to use for your chassis' and assign them one by one. If DHCP is chosen, then this is not required, but you may have trouble finding out what IP address the DHCP server assigned to each chassis, and it may change during a reboot of the chassis or DHCP server, so it is not recommended unless the DHCP server is set to assign static IP addresses to the unique MAC addresses of each chassis installed.
- f) There are several other options that can be set at this time, see Table 6 for a list.
- g) Select 'save changes' and reboot. The device will take approximately 90 seconds before it is responsive again. Remember that your PC/laptop must be set to the same subnet to 'see' it, so if you just assigned an IP address other than 192.168.0.x, then you will need to change your PC's IP again. It is recommended you change all chassis IP addresses before reverting your PC back to DHCP.

4.3. Web Interface

The MAXNET II chassis uses an integrated web page to supplement the SNMP management. All configuration of the chassis (static IP address, trap/email recipients, firmware upgrades, etc) must be done through the web page. Simply use any web browser (Internet Explorer, Firefox, etc) and enter the IP address of the chassis as the URL. Login as administrator to modify configuration and have full read/write access to monitor and control modules. Login as Operator to have full read/write access or login as observer to have read-only access. There is only one password per login level.

Parameter	Value	Properties
Model	MP3A	
Description	MN2 3RU Active Chassis	
Name	chassis	
Alias	<input type="text"/>	
Manufacturer	ATX	
Asset ID	<input type="text"/>	
Serial Number	00:40:9D:25:BD:2B	
Hardware Rev	DC-ME-01T-C	
Firmware Rev	1.0.9	

4.4. Module Replacement

In order to facilitate the replacement of any MAXNET II module, the software set-up information of the module such as HI and LO alarm thresholds and alias are stored in the chassis itself and not the module. If any module is removed the chassis and the same module or another of the same type is inserted into that slot of the chassis, then this configuration data will be maintained.

This is not true for switch parameters though. In order to meet switch time specifications at the module, this information is stored within the module itself and therefore will travel with it wherever it is installed next. These parameters include hysteresis, switch threshold, wait to restore time, etc.

4.5. Updating Active Chassis Firmware

- a) Login to web page interface of the chassis as an administrator.
- b) Check software status page for current rev level. If an upgrade is necessary, proceed with next steps.
- c) Go to Firmware tab
- d) Select 'HTTP Server' and verify it reads:
www.atxnetworks.com/firmware/MN2/image.bin
- e) Select Upload and wait for confirmation page to appear. The chassis will perform an MD5 checksum on the downloaded file to verify that no bit errors occurred.
- f) If you are updating a version prior to 1.4.2, then the calculated MD5 Checksum will be displayed on the screen. Contact Engineering at ATX to verify what this value should be (it will be the same for each chassis you upgrade with a given revision).
- g) If you are updating a chassis later than 1.4.2, then the checksum is verified automatically via a text file taken from the ATX web server.
- h) If md5checksum is verified, select Flash to memory. **Do not flash if it fails the MD5 checksum**, as this could permanently corrupt the memory.
- i) Wait approximately 5 seconds, then disconnect the network cable and proceed to the next chassis. **Leave the recently updated chassis powered** until it completes a reboot.
- j) Optionally, the chassis may now be factory reset to restore all IP settings to factory defaults. Read the Factory Reset section fully before doing this to know what data will be lost when doing this.

4.6. Factory Reset

A factory reset will restore the chassis to the state which it left the ATX production facility.

4.6.1. Parameters That Will be Changed

IP address = 192.168.0.1

NetMask = 255.255.255.0

Gateway = 192.168.0.254

Passwords set to same text (but all lower case) as the login level. e.g. Operator password is operator.

All analogue and discrete alarm thresholds of modules will be reset to default values (except RF and optical switch data as mentioned in the Module Replacement section above).

Alarm log will be cleared.

4.6.2. Purpose

Common reasons for requiring a factory reset are:

- a) The chassis is unresponsive, or the IP address is not known
- b) The Administrator password has been forgotten
- c) The yellow COMM LED does not blink after the 2 minute boot cycle, even after a power cycle or press of the RESET button

4.6.3. Method

If you are sure you want to factory reset, hold down the RESET button near the RJ45 port for at least 10 seconds. The yellow COMM LED will be solid-on during this time, and once it turns off you can release the button and the reboot process will begin.

4.7. SNMP Parameters

Display Name	Description
Hostname/ Domain Name	Optional fields.
IP Address, Subnet Mask, Default Gateway	Define the static IP address of the chassis. This address is maintained during power cycles and firmware upgrades. A factory reset will revert the IP back to 192.168.0.1
DNS Servers	Enter the domain name server to be able to enter textual URLs instead of only IP addresses. This affects how you can enter data in some fields below such as NTP server and SMTP server.
NTP Server	Network Time Server (e.g. time.windows.com). If there is no network time server available leave this blank. All times are then counting from midnight, Jan 1st, 1970 as the start-up time (this is an internet standard).
Time Zone	Only used if NTP server used. Adds local time zone offset to UTC time. e.g. for Eastern Standard Time Zone, enter 'UTC+5:0'.
Read-write Community Name	SNMP required variable.
Read-only Community Name	SNMP required variable.
Default Trap Community Name	SNMP required variable.
Trap Recipient List	List up to 10 IP addresses that are to receive SNMP traps (requires an SNMP trap receiver to interpret these alarm messages).
System Name, Location, Contact	Optional SNMP fields. User can store information about this particular chassis for reference later.
SMTP Server	Outgoing mail server. If you do not specify a DNS server above, then the server must be entered as an IP address.
Email Recipient List	List up to 5 email addresses that are to receive an email form of the traps.
SMTP Username, Password	If authentication required (ask your IT department), you must enter an email user name and password.

Table #6: Administration Level SNMP Parameters

Display Name	Description	HMS MIB Variable
Model	ATX model number (note, in empty slots you can enter passive, dual-passive, or empty to populate the overview page with passive picture placeholders).	entPhysicalModelName
Description	Description of the module.	entPhysicalDescr
Name	Indicates the slot of the chassis the module is in.	entPhysicalName
Alias	Optional user defined field - added to fifth variable binding of traps and emails e.g. set this to "Node 69" for a given Receiver and any alarms generated by this receiver will have "Node 69" in the description. Otherwise, it would only contain the IP address of the chassis, the Model and Name (slot number).	entPhysicalAlias
Manufacturer	ATX	entPhysicalMfgName
Asset I.D	Optional user settable field (suggestions: enter in a custom serial number or purchase order # for tracking).	entPhysicalAssetID
Serial No	Module's serial number.	entPhysicalSerialNum
Hardware Rev	Hardware rev of module.	entPhysicalHardwareRev
Firmware Rev	Firmware rev of module.	entPhysicalFirmwareRev
Temperature [C]	Module's current heatsink temperature.	heCommonTemperature
Alarm Detection Control	detectionEnabled: normal operation, with active alarms detectionDisabled: used to temporarily disable alarms/traps from this module detectionEnabledandRegenerate: enter detectionEnabled state while regenerating all alarm table entries	heCommonAlarmDetectionControl
Fan Unit Status	Alarm status of the fan.	heFanUnitAlarm
Voltage In [Volt]	Measured voltage supplied to the module from the chassis (nominally 24V).	hePsUnitVoltageIN
Current In [mA]	Current taken from the 24V rail by the module.	hePsUnitCurrentIN
Power In [Watts]	P.S. Voltage * P.S. Current	hePsUnitPowerIN

Table #7: Common Module SNMP Parameters

Display Name	Description	HMS MIB Variable
Switch Mode	Automatic : switching based on threshold Manual : switch forced to Default position	heRFSwitchMode / heOpSwitchMode
Switch Control	Default position of switch (PathA or PathB only).	heRFSwitchControl / heOpSwitchControl
Switch Revert Enable	On: switch will revert back to default position if power returns to it (also, must be in automatic mode and hysteresis accounted for).	heRFSwitchRevertEnable / heOpSwitchRevertEnable
Switch State	Current position of the switch (PathA or PathB only).	heRFSwitchState / heOpSwitchState
Switch Fail-Over Status	Fault if RF Sw Control not equal to RF/Opt Sw State.	heRFSwitchFailoverStatus / heOpSwitchFailoverStatus
Switch Both Input Status	Fault if either switch input is below RF/Opt Sw Input Power Threshold.	heRFSwitchBothInputStatus / heOpSwitchBothInputStatus
Switch Hysteresis [dB]	Only values ≥ 0 are acceptable. e.g. If 2 dB , switch will occur if power falls below RF Sw Input Power Threshold, but does not return until power exceeds RF Sw Input Power Threshold + 2 dB (*must also be in automatic mode, revert-enable on and wait to restore time expired).	heRFSwitchHysteresis / heOpSwitchHysteresis
Switch Wait to Restore Time [sec]	Time-based hysteresis. Same principle as above, but time delayed switching if default path power returns.	heRFSwitchWaitToRestoreTime / heOpSwitchWaitToRestoreTime
Switch Input Level	Measured input level of switch.	heRFSwitchInputRFLevel / heOpSwitchInputRFLevel
Switch Input Power Threshold [dBm]	User defined switch threshold.	heRFSwitchSetInputPowerThreshold / heOpSwitchSetInputPowerThreshold
Switch Output Description	Description of the output.	heRFSwitchOutputDescription / heOpSwitchOutputDescription
Switch Wavelength	Optional, user-settable integer to store the wavelength of operation. This value has no effect on the operation of the device.	heOpSwitchSelectWavelength
Switch Input Status	If RF/Opt Input power is below the input power threshold, then this discrete variable will be in fault, generating an alarm condition.	heRFSwitchInputStatus / heOpSwitchInputStatus
Switch Input Description	Identifies inputs as either path A or path B.	heRFSwitchInputDescription / heOpSwitchInputDescription

Table #8: RF and Optical Switch SNMP Parameters

Display Name	Description	HMS MIB Variable
Input AGC Mode	Automatic Gain Control mode, if set to on then the broadcast digital attenuator is automatically adjusted to provide RF power levels at laser input for optimum OMI.	heOpTxInputAGCMode
Input Modulation Mode	Either CW or modulated. This variable affects the calibration of the RF power detector. There is approx a 2 dB difference seen by the power detector if a CW or modulated carrier of the same power is applied.	heOpTxInputModulationMode
Input Attenuation, BC Input Attenuation, NC	Input digital attenuators. See MPTX functional diagrams to see location of the BC (Broadcast) and NC (Narrowcast) attenuators. 0-15 dB in 0.5 dB steps.	heOpTxInputRFPadLevel
Laser Temperature	Laser Temperature.	heOpTxLaserTemp
Laser Bias Current	Laser Bias Current.	heOpTxLaserBiasCurrent
Laser Output Power	If a 10dBm laser is ordered, this variable will be close to 10 dB, with some variation as individual lasers are tuned for optimum OMI.	heOpTxLaserOutputPower
Laser TEC Current	Thermo-Electric cooler current.	heOpTxLaserTECCurrent
Laser Type	Typically "Cooled DFB".	heOpTxLaserType
Laser Wavelength	Optional, user-settable integer to store the wavelength of operation. This value has no effect on the operation of the device.	heOpTxLaserWavelength
Laser Output Status	A read-only field to indicate what Laser On/Off control is set to.	heOpTxLaserOutputStatus
Laser On/Off Control	A writable field. Laser is muted if set to off.	heOpTxLaserOnOffControl

Table #9: MPTX Laser SNMP Parameters

Display Name	Description	HMS MIB Variable
OptRx Input Power	Measured optical power input (max +3dBm).	heOpRxInputPower
OptRx Input Wavelength	Optional, user-settable integer to store the wavelength of operation. This value has no effect on the operation of the device.	heOpRxInputWavelengthControl
OptRx Input Status	If optical input power is beyond thresholds, this will be in <i>fault</i> condition.	heOpRxInputStatus
OptRx Output Control	Allows the user to mute the RF output.	heOpRxOutputControl
OptRx Output RF Attenuation	Control of RF output attenuation level (0-31.5 dB in 0.5 dB steps).	heOpRxOutputRFPadLevel
RF Amp Output Description	Description of the approx gain value of the amp.	heRFAmpOutputDescription
RF Amp Output Level [dBm]	Composite RF level at output of amp.	heRFAmpOutputLevel
Voltage Out	Measured voltage supplied to the chassis. (power supply modules only)	hePsOutputVoltage
Current Out	Current supplied to the 24V rail by the module. (power supply modules only)	hePsOutputCurrent
Power Out	Voltage Out * Current Out. (power supply modules only)	hePsOutputPower

Table #10: Misc SNMP Parameters

4.8. SNMP MIBs Required

	RFC
MIB-II	1213
Entity MIB (Version 2)	2737
SNMP-Notification	3413
SNMP-Target	3413
SNMP-Framework	3411

Table #11: General IETF MIBs Required - All Modules

	HMS#	SCTE#
SCTE-ROOT	028	36
SCTE-HMS-ROOTS	072	37
SCTE-HMS-HEADENDIDENT-MIB	114	38-11
SCTE-HMS-HE-COMMON-MIB	111	84-1
SCTE-HMS-PROPERTY-MIB	026	38-1
SCTE-HMS-HE-FAN-MIB	117	84-3
SCTE-HMS-HE-POWER-SUPPLY-MIB	116	84-2

Table #12: General SCTE HMS MIBs Required - All Modules

	HMS#	SCTE#	MAXNET II Modules:
SCTE-HMS-HE-OPTICS-MIB	108	83-1	All modules with fiber optics
SCTE-HMS-HE-OPTICAL-RECEIVER-MIB	113	85-2	MPRX-DC, MPRX-8, MPRX-16, MPRX2-8, MPRXRR-8, MPRXRR-16
SCTE-HMS-HE-OPTICAL-TRANSMITTER-MIB	112	85-1	MPTX
SCTE-HMS-HE-RF-MIB	133	83-4	QMP, MPRFA/B
SCTE-HMS-HE-RF-AMP-MIB	131	94-1	QMP
SCTE-HMS-HE-RF-SWITCH-MIB	132	94-2	MPRFA/B

Table #13: Module-Specific SCTE HMS MIB's Required

*freely download any SCTE MIB's from www.scte.org/standards

This page left intentionally blank.

MAINTENANCE & TROUBLESHOOTING

5. Maintenance & Troubleshooting

5.1. Maintenance

Daily, ensure that the Power LED's are on for all of the modules and that there are no Alarm lights. Ensure that the yellow 'COM' LED near the rear RJ45 port is blinking.

Weekly, ensure that all module cooling fans are operational and unobstructed.

Monthly, vacuum all module cooling fans.

5.2. Troubleshooting

The following guide will help the operator to diagnose problems in active modules or chassis'. If none of the items in this section are of help, please contact ATX for Technical Support.

5.2.1. Slow Flashing Red LED on Module Front

If any alarm LED on the front of the module is blinking at a rate of approximately 1 second ON, 1 second OFF, then this is indicative of a slot addressing communications failure. RF and Optical functionality will likely still work, but the unit will have no software monitoring or control during this time.

Try removing the module and replacing it. If this does not fix the problem, then switch the module to a different slot in the chassis. If the red LEDs return to normal operation, then the problem is in actual slot of the chassis and likely the connector on the back rail is damaged. Contact ATX and report a defective chassis.

If this does not fix the problem then contact ATX and report a defective module.

5.2.2. Chassis' Yellow COM LED Not Blinking

It is normal for the round LED near the RJ45 port at the rear of the chassis to be solid ON or OFF during various states of system boot-up. If the chassis has been powered up (solid green on the round "+24V" LED near the terminal block at the rear of the chassis) for at least 2 minutes, then the yellow LED should be blinking to indicate the chassis software is running. If it is not, a reboot is necessary.

If the chassis can be interrupted briefly, then simply remove power to it by pulling all MPAC/MPDC modules out part-way.

If the chassis must remain live then try pressing the black RESET button near the RJ45 port. If this does not work, then the communications module itself can be removed from the back of the chassis. Remove the two Phillips screws that hold the module on, then pull it off and replace it. This will not interrupt the operation of the modules within the chassis.

If this still does not start the yellow LED blinking after boot-up, then a factory reset will be necessary. See Section 4.6.

5.2.3. No Response From Chassis Over Network

Typically, this is a 'subnet' issue. In order for any device to see another device on the same network, they must be on the same subnet. Consult your IT department for details of your network, but typically the subnet refers to the first three of the four octets in an IP address. E.g. if the computers in your network are given IP addresses of 192.168.10.1 through 192.168.10.250, then the subnet is the 192.168.10 part.

Each MAXNET II chassis ships with a default IP of 192.168.0.1, so the PC connected to it must have an IP address of 192.168.0.x where x is not equal to 1. This is not generally the case, so it must be forced.

To modify the PC's IP in Windows, choose Start -> Settings -> Network Connections -> Local Area Connection -> Properties -> Internet Protocol (TCP/IP).

If the chassis IP is no longer at the default IP, modify the subnet portions of these settings (IP address and Default Gateway) to match.

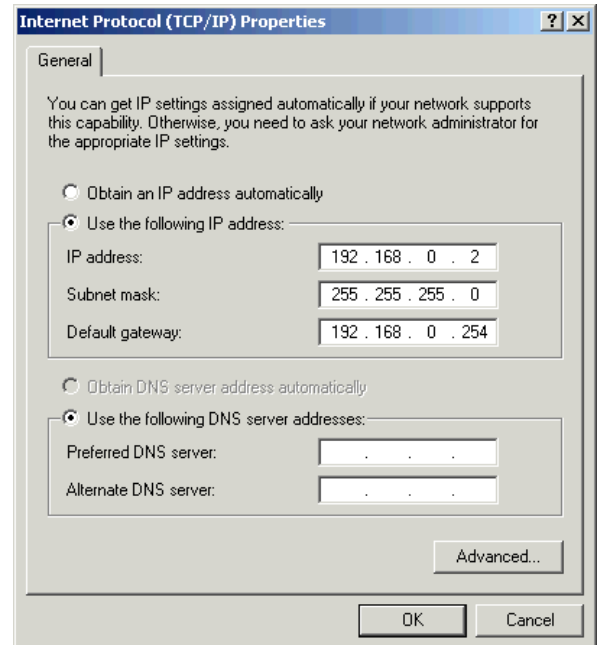

If the chassis is still not visible, it is possible the IP address of the chassis has been forgotten (see Factory Reset section), the network connection is not good (see Ethernet Port section for LED diagnostics) or a network port is blocked or firewalled (check with your IT department).

5.2.4. Some Modules Do Not Show Up On Web Page

If the chassis is visible on the web or through SNMP walks, but one or more installed modules is not, try removing and replacing the module in a different slot. Verify that the green power LED is solid and the red LED is either off or blinking quickly (approx half second on, half second off). If the LED's are not as stated, see the appropriate troubleshooting section.

5.2.5. Module Power LED Off or Intermittent

Check the '24V' green LED on the rear of the chassis. If it is off, then the problem is that the chassis is not getting power. See MPAC/MPDC troubleshooting section. If it is on or if other modules in the chassis are okay, the module itself is suspect. Continue.

Remove the suspect module and trade slot positions with another functioning module.

- a) If the suspect module is okay and the previously good module fails, contact ATX and report a defective chassis.
- b) If the suspect module fails and the previously good module is okay, contact ATX and report that the suspect module is defective.

5.2.6. MPAC/MPDC Not Powering Chassis

*Note that 220 VAC applied to an MPAC-110 will damage the module, but 110 VAC applied to an MPAC-220 will simply not turn on.

- a) Check the fuse continuity on the MPAC or MPDC module
- b) Verify that the 110 VAC / 220 VAC electrical outlet is active using a voltmeter and checking the circuit breaker. (In the case of the MPDC insure that there is -48 VDC on the rear terminal block)
- c) Verify that IEC power cord is properly inserted into the receptacle on the rear of the module and properly connected to a 110 VAC / 220 VAC electrical outlet.

5.2.7. Module Will Not Insert Fully Into Chassis

- Remove the module and inspect it for damage or bent guide rails. Check active modules for damage to the power connector at the rear of the unit.
- Inspect the chassis for bent metal or obstructions.
- Be sure that the active module is inserted such that the module guide is in an odd numbered slot i.e. (left side of module is above an odd numbered slot and the right side is above an even number slot).
- Try the module in a different slot. Due to machinery tolerances, some modules may be more snug in some slots than others. If the tolerances are unacceptable, contact ATX.

5.2.8. Temperature/Fan Fault Alarm on Any MAXNET® II Active Module

Check to see if the module fan is operating. If not replace with a new fan from ATX (Fan Part #: MPFANA) using the below procedure.



- Remove two screws holding plate and fan in place.

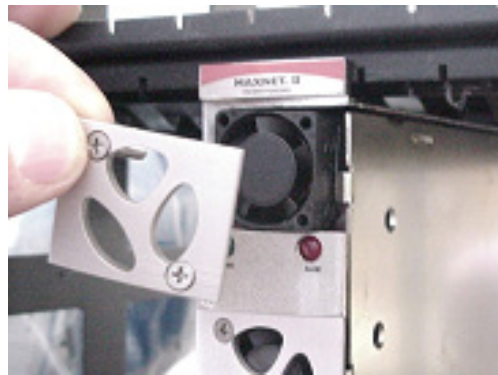

- Remove fan cover and screws.



- Pull out fan with tweezers.

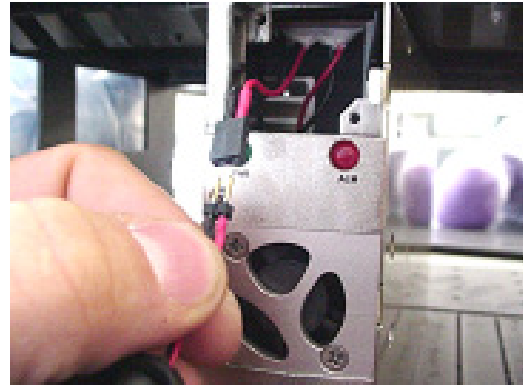

- Remove push-fit power connections.

- Install replacement fan in the opposite order shown. Ensuring that:
 - The red and black wires are aligned.
 - The labelled side of the fan faces inward toward the module
 - The wires do not bunch up behind the fan, interfering with fan rotation.

This page left intentionally blank.

SERVICE & SUPPORT

6. Service & Support

6.1. Contact ATX Networks

Please contact ATX Technical Support for assistance with any ATX products. Please contact ATX Customer Service to obtain a valid RMA number for any ATX products that require service and are in or out-of-warranty before returning a failed module to the factory.

ATX Networks
1-501 Clements Road West
Ajax, ON L1S 7H4 Canada

Tel: (905) 428-6068
Toll Free: (800) 565-7488
Fax: (905) 427-1964
Toll Free Fax: (866) 427-1964
Web: www.atxnetworks.com
E-mail: support@atxnetworks.com

6.2. Warranty Information

All of ATX Networks' products have a 1-year warranty that covers manufacturer's defects or failures.

6.3. Safety

IMPORTANT! FOR YOUR PROTECTION, PLEASE READ THE FOLLOWING:

Water and Moisture: Care should be taken so that objects do not fall and liquids are not spilled into the enclosure through openings.

Power Sources: The device should be connected to a power supply only of the type described in the operating instructions or as marked on the device.

Grounding or Polarization: Precautions should be taken so that the grounding or polarization means of the device is not defeated.

NOTE: A separate connection shall be made to ground the chassis using the ground bonding lug provided on the rear of the chassis. This connection should be protected from breakage and abuse.

Power Cord Protection: Power supply cords should be routed so that they are not likely to be pinched by items placed upon or against them, paying particular attention to cords at plugs, convenience receptacles, and the point where they exit from the device.

Servicing: The user should not attempt to service the device beyond that described in the operating instructions. All other servicing should be referred to qualified service personnel.

Fusing: If your device is equipped with a fused receptacle, replace only with the same type fuse. Refer to replacement text on the unit for correct fuse type.

Recommended external fusing of the MPDC supply to be limited to 10 Amps.

The MPAC-110 Power Supply receptacle fuse rating is 6.3 Amps 250 Volts slo blo.

The MPAC-220 Power Supply fuse rating is 3.15 Amps 250 Volt slo blo.

CAUTION: For continued protection against the risk of fire, replace only with the same type and rating of fuse.

Power Supply Removal: Power (AC or DC) should be disconnected from the module before removing for replacement or service. This is accomplished by removing the AC IEC plug for the MPAC unit and the terminal block for the MPDC unit. To remove a power supply module from the chassis, gently lift the front handle and pull back on the module until it is clear of the chassis guide slot.

ERRATA (14 May 2008)

The Optical Transmitter modules MPTXxxx referenced in this manual for use in the MP3xxx Chassis are pending acceptance by UL.



1-501 Clements Road West, Ajax, ON L1S 7H4 Canada
Tel +1 (905) 428-6068 Toll Free +1 (800) 565-7488 Fax +1 (905) 427-1964 Toll Free Fax +1 (866) 427-1964
www.atxnetworks.com support@atxnetworks.com