



---

**MAXNET® II**

*Platinum Series*

Pat.# U.S. 7,142,414

**MPAC / MPDC  
Modular Power Supply Manual**



# TABLE OF CONTENTS

	<b>Page</b>
<b>1. PRODUCT DESCRIPTION .....</b>	<b>1-1</b>
1.1. Functional Diagrams.....	1-2
1.2. Technical Specifications .....	1-3
<b>2. INSTALLATION .....</b>	<b>2-1</b>
2.1 Product Inspection.....	2-1
2.2. Module Installation Into the Active MAXNET® II Chassis .....	2-1
2.3. DC Redundant Powering of Active MAXNET® II Chassis .....	2-2
2.4. Remote Powering of Additional Active MAXNET® II Chassis' .....	2-2
2.5. Module Power Requirements .....	2-3
2.6 LED Indicators .....	2-3
<b>3. STATUS MONITORING .....</b>	<b>3-1</b>
3.1. Chassis Interface Options .....	3-1
3.2. SCTE HMS MIB Software Definition of Module.....	3-1
3.3. Web Interface .....	3-1
3.4. Updating Active Chassis Firmware.....	3-2
3.5. Factory Reset .....	3-2
<b>4. STATUS MONITORING FEATURES .....</b>	<b>4-1</b>
4.1. SNMP Parameters.....	4-1
4.2. SNMP MIBs Required for MPAC & MPDC .....	4-2
<b>5. MAINTENANCE &amp; TROUBLESHOOTING.....</b>	<b>5-1</b>
5.1. Maintenance .....	5-1
5.2. Troubleshooting.....	5-1
<b>6. SERVICE &amp; SUPPORT.....</b>	<b>6-1</b>
6.1. Contact ATX Networks.....	6-1
6.2. Warranty Information .....	6-1
6.3. Safety .....	6-1

# Index of Figures and Tables

## **Figures**

#1 MPAC Power Supply Functional Diagram .....	1-2
#2 MPDC Power Supply Functional Diagram.....	1-2
#3 Front & Rear Panel Pictures.....	2-2
#4 Remote Powering .....	2-2
#5 Redundant Powering .....	2-2

## **Tables**

#1 Ordering Information.....	1-1
#2 Technical Specifications .....	1-3
#3 Rear Terminal Block Assignments .....	2-1
#4 LED Status Indications .....	2-3
#5 Common Module SNMP Parameters .....	4-1
#6 MPAC & MPDC SNMP Parameters.....	4-1
#7 SCTE HMS MIBs Required .....	4-2

# PRODUCT DESCRIPTION

## 1. Product Description

The MPAC and MPDC are modular power supplies that supply the required +24 VDC to the MAXNET II Active Chassis back plane. This allows any MAXNET II active module (RPR's, FPT's, AMP's, RF switcher) to be installed in any remaining active chassis slot to receive power. Both MPAC and MPDC have 24 VDC redundant powering capabilities, although only the MPDC offers true load sharing logic. Installing two power supply modules into a chassis will thus ensure power to the backplane if one of them fails. Both the MPAC and MPDC include a 24 VDC rear terminal block connection for remote powering options. The MPAC and MPDC power supply modules are dual-width, taking up two slots in the Active MAXNET II Chassis. They are connected to the Active MAXNET II Chassis through a hot-swapping backplane. The MPAC and MPDC modules feature the standard MAXNET II functionality including front panel power and alarm LED indicators as well as the capability of module status monitoring through SNMP based Managers. The MAXNET II SNMP interface is HMS compliant.

Please refer to the web page for up-to-date specifications – [www.atxnetworks.com](http://www.atxnetworks.com)

Part Number	Description
MPAC-110	110 VAC to 24 VDC 250W Power Supply
MPAC-220	220 VAC to 24 VDC 250W Power Supply
MPDC	-48 VDC to 24 VDC 250W Power Supply

**Table #1: Ordering Information**

### 1.1. Functional Diagrams

ATTENTION: NOT A UNIVERSAL VOLTAGE INPUT ! REFER TO ORDERING INFORMATION FOR DETAILS

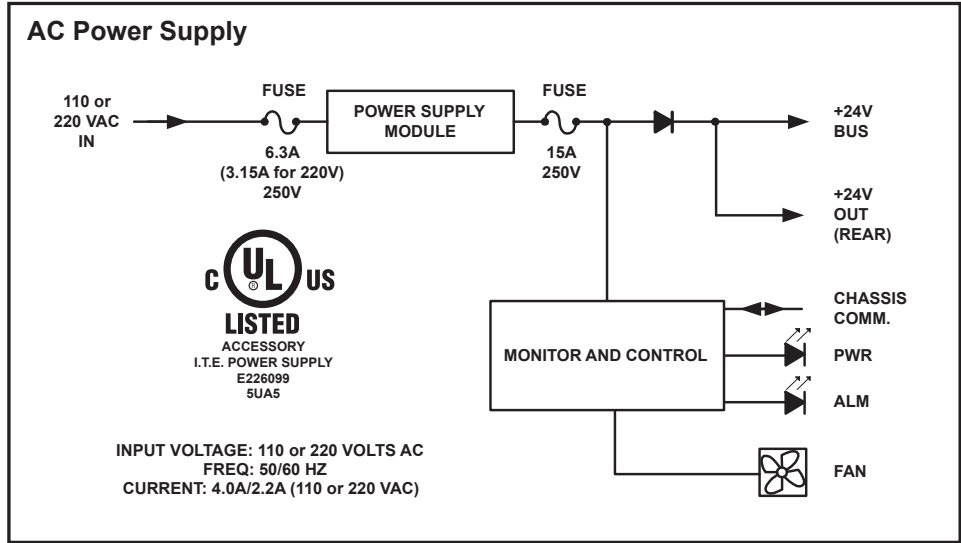

Figure #1: MPAC Power Supply Functional Diagram

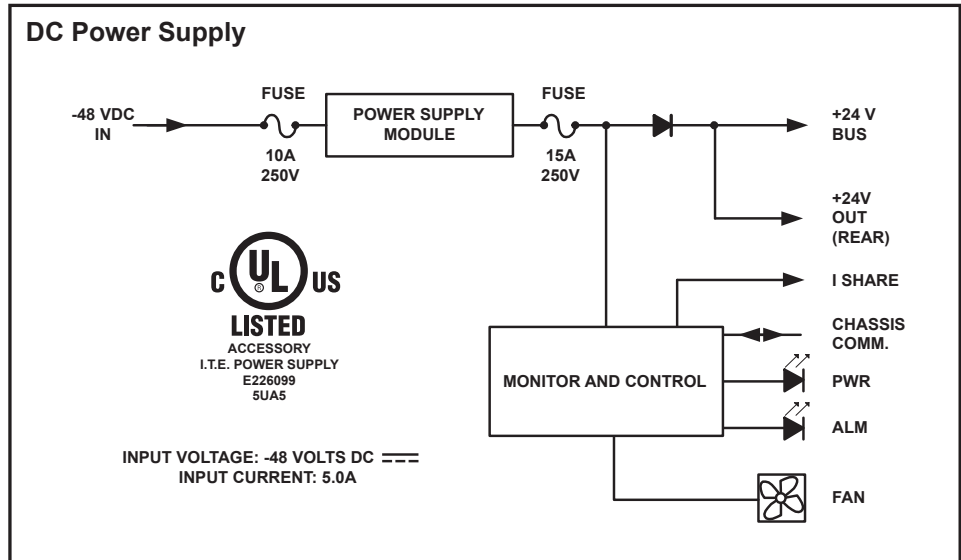

Figure #2: MPDC Power Supply Functional Diagram

## 1.2. Technical Specifications

ELECTRICAL SPECIFICATIONS	MPAC-110	MPAC-220	MPDC
<b>INPUT</b>			
INPUT VOLTAGE	110 VAC +/- 10%	220 VAC +/- 10%	-48.0 +/- 12.0 VDC
FREQ	50/60 Hz	50/60 Hz	DC
INPUT CURRENT (Max)	4.0 Amps AC	2.2 Amps AC	5.0 Amps DC (-48 VDC)
POWER FACTOR	> 0.6	> 0.6	NA
EFFICIENCY	> 0.8	> 0.8	> 0.8
<b>OUTPUT</b>			
OUTPUT VOLTAGE	24.0 +/- 1.0 VDC	24.0 +/- 1.0 VDC	24.0 +/- 1.0 VDC
DC OUTPUT CURRENT (Max)	8 Amps	8 Amps	8 Amps
RIPPLE VOLTAGE (Max)	200 mV P-P	200 mV P-P	200 mV P-P
MAXIMUM POWER OUTPUT	250 W	250 W	250 W
<b>OTHER</b>			
APPROVALS	Component: cULus, FCC Entire Module: Approvals Pending (cULus, FCC, CE)	Component: cULus, FCC Entire Module: Approvals Pending (cULus, FCC, CE)	Component: cULus, FCC Entire Module: Approvals Pending (cULus, FCC, CE)
24V POWER INDICATOR	Front: Green LED	Front: Green LED	Front: Green LED
ALARM STATUS	Front: Red Flash LED	Front: Red Flash LED	Front: Red Flash LED
TERMINAL BLOCK WIRING	# 12 AWG	# 12 AWG	# 12 AWG

Table #2: Technical Specifications

This page left intentionally blank.

# INSTALLATION

## 2. Installation

### 2.1. Product Inspection

Carefully unpack the power supply module from the shipping box. If the box or power supply module is damaged, please notify the freight company to make a damage claim. If you suspect that there is a problem with the power supply module that may affect its safe operation, do not install such a suspect Power Supply into the Active MAXNET II Chassis.

**NOTE:** This equipment is intended for installation in a **RESTRICTED ACCESS LOCATION** only.

**NOTE:** Not for use in a computer room as defined in the Standard for Protection of Electronic Computer/Data Processing Equipment, ANSI/NFPA 75.

#### Rack Mounting Precautions

- Elevated Operating Ambient** - If installed in a closed or multi-unit rack assembly, the operating ambient temperature of the rack environment may be greater than room ambient. Therefore, consideration should be given to installing the equipment in an environment compatible with the maximum ambient temperature (35°C) specified by the manufacturer.
- Reduced Air Flow** - Installation of the equipment in a rack should be such that the amount of airflow required for safe operation of the equipment is not compromised.
- Mechanical Loading** - Mounting of the equipment in the rack should be such that a hazardous condition is not achieved due to uneven mechanical loading.
- Circuit Overloading** - Consideration should be given to the connection of the equipment to the supply circuit and the effect that overloading of the circuits might have on overcurrent protection and supply wiring. Appropriate consideration of equipment nameplate ratings should be used when addressing this concern.
- Reliable Earthing** - Reliable earthing of rack-mounted equipment should be maintained. Particular attention should be given to supply connections other than direct connections to the branch circuit (e.g. use of power strips)."

### 2.2. Module Installation Into the Active MAXNET® II Chassis

Slide the dual-width MPAC or MPDC power supply module into an open slot in the Active MAXNET II Chassis, one that spans two single-width module locations beginning with an odd number (indicated by a white marker on the chassis), until the module drops into its lock position. **The module must be inserted into an odd number slot in order for the power supply module to properly mate to the active chassis back plane.** If the power supply is an MPAC unit, connect an appropriate power cord (depending on the voltage rating used and plug type at installation site) to MPAC's IEC power inlet. If the power supply is an MPDC unit, using bus wire, connect -48 VDC into the terminal block on the back of the module following the terminal block labelling (see below Table 3). A disconnect device is required between the -48 VDC supply and the MPDC power supply.

To remove a power supply module from the chassis, gently lift the front handle and pull back on the module until it is clear of the chassis guide slot. Power (AC or DC) should be disconnected from the module before removing for replacement or service. This is accomplished by removing the AC IEC plug for the MPAC unit and the terminal block for the MPDC unit.

TB#	MPAC-110	MPAC-220	MPDC
1	GND	GND	GND
2	COM (1)	COM (1)	COM (1)
3	+24V OUT (1)	+24V OUT (1)	+24V OUT (1)
4			RTN
5			-48V
1. 24V output on rear panel terminal block allows for remote powering to other MAXNET II active chassis			

Table #3: Rear Terminal Block Assignments

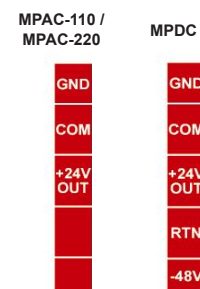

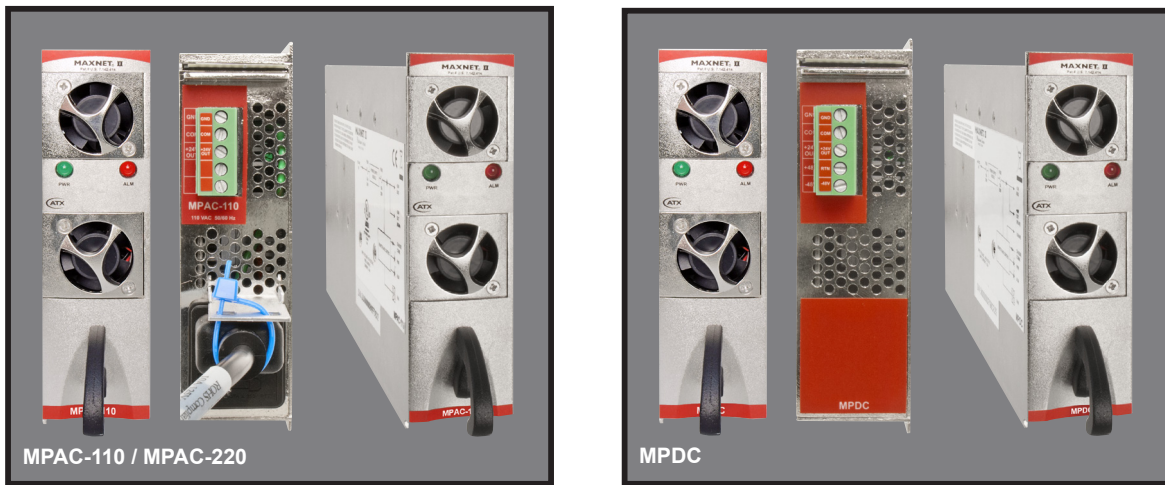

Figure #3: Front & Rear Panel Pictures

### 2.3. DC Redundant Powering of Active MAXNET® II Chassis

If more than one power supply is connected to the chassis, the extra power supply acts as a redundant source of power. Using internal logic within the module (MPAC uses diode steering, MPDC uses load sharing logic) if the main power supply on the chassis fails, the other power supply becomes the active supplier to the +24 VDC chassis bus rail ensuring power is always maintained to all active modules in the chassis.

### 2.4. Remote Powering of Additional Active MAXNET® II Chassis'

Both the MPAC and MPDC power supplies include the ability to remotely power additional MAXNET II chassis' by connecting bus wire to pin 2 (COM) and 3 (+24V) on the rear terminal block.

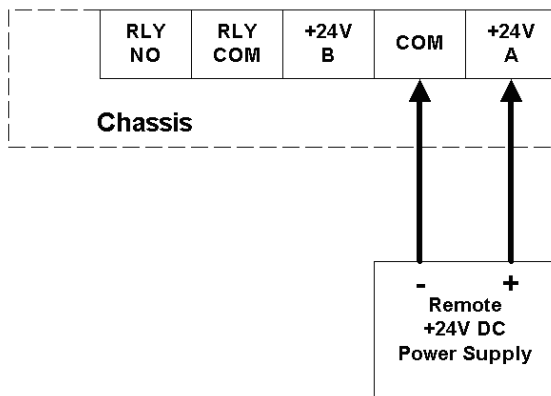

Figure #4: Remote Powering

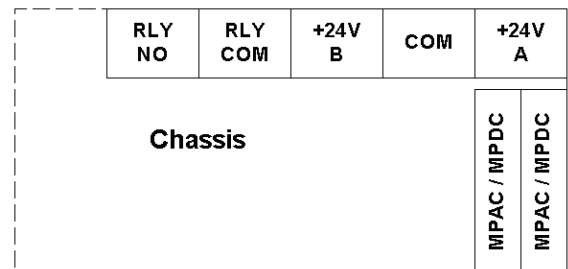

Figure #5: Redundant Powering

\* In any of the examples above, be sure to refer to the next section for module power requirements. In any redundant scenario, if a power supply fails, the load on any remaining power supply must not exceed 8 amps.

## 2.5. Module Power Requirements

Module	MPAC / MPDC	MPRX-8 / MPRX-16	MPRX2-8	MPRXRR-16 / MPRXRR-8	MPRX-DC / MPRX2-DC	MPRX2-DC	MPRFA/B	QMP200	QMP1000 (< 22 dB Gain)	QMP1000 (> 22 dB Gain)
<b>Max Current (A)</b>	8	0.29	0.52	0.46	0.29	0.52	0.03	0.14	0.47	0.52

## 2.6. LED Indicators

The MPAC and MPDC power supply module have two LED indicators: PWR and ALM.

- The PWR (Power) LED verifies, by lighting solid green, that the power supply is supplying 24 VDC powering to the active MAXNET II chassis.
- The ALM (Alarm) LED will flash red if there is a problem with the power supply or if any of its monitored functions are beyond the specified limits.

		STATUS		
		FLASHING RED <sup>1</sup>	SOLID GREEN	OFF
LED	PWR	N/A	24V Power ON	Check Power Supply Module
	ALM	Module problem	N/A	Normal (PWR is GREEN)

Table #4: LED Status Indications

<sup>1</sup> If the ALM LED is flashing red at a slow rate of approximately 1s on-1s off, this is indicative of a communications failure between this module and the chassis. See Troubleshooting section.

This page left intentionally blank.

# STATUS MONITORING

## 3. Status Monitoring

### 3.1. Chassis Interface Options

The Active MAXNET II product line can be monitored and controlled in either of two ways:

- a) A free, web-based interface. This comes pre-installed on every chassis and provides a user friendly method of configuring the administrative set-up and all monitoring and control. It is based on SNMP, but requires little knowledge of SNMP. Any internet browser, such as Internet Explorer, is all the software that is required.
- b) Any third-party SNMP Management software (e.g. [www.castlerock.com](http://www.castlerock.com), [www.ndt-inc.com/SNMP/MIBrowser.html](http://www.ndt-inc.com/SNMP/MIBrowser.html)) may be purchased separately. These suites tend to be expensive and not as user friendly as the web interface. The web interface is also still required for administrative set-up. The 3rd party interface is recommended only for systems that have an existing SNMP architecture. All MIBs (Management Information Bases) are freely downloadable from the SCTE ([www.scte.org/standards](http://www.scte.org/standards)). ATX was able to support all modules using the SCTE standard HMS MIBs, so no custom MIBs are required.

### 3.2. SCTE HMS MIB Software Definition of Module

The power supply module uses the headend power supply MIB to support voltage and current measurements of what it is providing to the chassis' backplane.

### 3.3. Web Interface

The MAXNET II chassis uses an integrated web page to supplement the SNMP management. All configurations of the chassis (static IP address, trap/email recipients, firmware upgrades, etc) must be done through the web page. Simply use any web browser (Internet Explorer, Firefox, etc) and enter the IP address of the chassis as the URL. Login as administrator to modify configuration and have full read/write access to monitor and control modules. Login as Operator to have full read/write access or login as observer to have read-only access. There is only one password per login level.

Parameter	Value	Properties
Model	MPAC-110	
Description	110V AC Power Supply	
Name	Module in Slot 1	
Alias	<input type="text"/>	
Manufacturer	ATX	
Asset ID	<input type="text"/>	
Serial Number	5D-00-00-00-0E-F4-5D-22	
Hardware Rev	1.9	
Firmware Rev	1.9	
Temperature [C]	29.0	Analog
Alarm Detection Control	<input type="text" value="detectionEnabled"/>	
P.S. Description	110V AC	
Voltage Out [V]	24.5	Analog
Current Out [mA]	2851	Analog
Power Out [W]	69.84	Analog
Fan Unit Status	normal	Discrete

### 3.4. Updating Active Chassis Firmware

- a) Login to web page interface of the chassis as an administrator.
- b) Check software status page for current rev level. If an upgrade is necessary, proceed with next steps.
- c) Go to Firmware tab.
- d) Select 'HTTP Server' and verify it reads:  
[www.atxnetworks.com/firmware/MN2/image.bin](http://www.atxnetworks.com/firmware/MN2/image.bin)
- e) Select Upload and wait for confirmation page to appear. The chassis will perform an MD5 checksum on the downloaded file to verify that no bit errors occurred.
- f) If you are updating a version prior to 1.4.2, then the calculated MD5 Checksum will be displayed on the screen. Contact Engineering at ATX to verify what this value should be (it will be the same for each chassis you upgrade with a given revision).
- g) If you are updating a chassis later than 1.4.2, then the checksum is verified automatically via a text file taken from the ATX web server.
- h) If md5checksum is verified, select Flash to memory. **Do not flash if it fails the MD5 checksum**, as this could permanently corrupt the memory.
- i) Wait approximately 5 seconds, then disconnect the network cable and proceed to the next chassis. **Leave the recently updated chassis powered** until it completes a reboot.
- j) Optionally, the chassis may now be factory reset to restore all IP settings to factory defaults. Read the Factory Reset section fully before doing this to know what data will be lost when doing this.

### 3.5. Factory Reset

A factory reset will restore the chassis to the state which it left the ATX production facility.

#### 3.5.1. Parameters That will be Changed

IP address = 192.168.0.1

NetMask = 255.255.255.0

Gateway = 192.168.0.254

Passwords set to same text (but all lower case) as the login level. e.g. Operator password is operator.

All analogue and discrete alarm thresholds of modules will be reset to default values.

Alarm log will be cleared.

#### 3.5.2. Purpose

Common reasons for requiring a factory reset are:

- a) The chassis is unresponsive, or the IP address is not known
- b) The Administrator password has been forgotten
- c) The yellow COMM LED does not blink after the 2 minute boot cycle, even after a power cycle or press of the RESET button

#### 3.5.3. Method

If you are sure you want to factory reset, hold down the RESET button near the RJ45 port for at least 10 seconds. The yellow COMM LED will be solid-on during this time, and once it turns off you can release the button and the reboot process will begin.

# STATUS MONITORING FEATURES

## 4. Status Monitoring Features

### 4.1. SNMP Parameters

Display Name	Description	HMS MIB Variable
Model	ATX model number (note, in empty slots you can enter passive, dual-passive, or empty to populate the overview page with passive picture placeholders).	entPhysicalModelName
Description	Description of the module.	entPhysicalDescr
Name	Indicates the slot of the chassis the module is in.	entPhysicalName
Alias	Optional user defined field - added to fifth variable binding of traps and emails e.g. set this to "Node 69" for a given Receiver and any alarms generated by this receiver will have "Node 69" in the description. Otherwise, traps would only contain the IP address of the chassis, the Model and Name (slot number).	entPhysicalAlias
Manufacturer	ATX	entPhysicalMfgName
Asset I.D	Optional user settable field (suggestions: enter in a custom serial number or purchase order # for tracking).	entPhysicalAssetID
Serial No	Module's serial number.	entPhysicalSerialNum
Hardware Rev	Hardware rev of module.	entPhysicalHardwareRev
Firmware Rev	Firmware rev of module.	entPhysicalFirmwareRev
Temperature [C]	Module's current heatsink temperature.	heCommonTemperature
Alarm Detection Control	detectionEnabled: normal operation, with active alarms detectionDisabled: used to temporarily disable alarms/ traps from this module detectionEnabledandRegenerate: enter detectionEnabled state while regenerating all alarm table entries	heCommonAlarmDetectionControl
Fan Unit Status	Alarm status of the fan.	heFanUnitAlarm

Table #5: Common Module SNMP Parameters

Display Name	Description	HMS MIB Variable
Voltage Out [Volt]	Measured voltage supplied to the chassis from the MPAC or MPDC	hePsOutputVoltage
Current Out [mA]	Current supplied to the 24V rail by the module	hePsOutputCurrent
Power Out [Watts]	Voltage Out * Current Out	hePsOutputPower

Table #6: MPAC & MPDC SNMP Parameters

## 4.2. SNMP MIBs Required for MPAC & MPDC

	<b>HMS#</b>	<b>SCTE#</b>
SCTE-ROOT	028	36
SCTE-HMS-ROOTS	072	37
SCTE-HMS-HEADENDIDENT-MIB	114	38-11
SCTE-HMS-HE-COMMON-MIB	111	84-1
SCTE-HMS-PROPERTY-MIB	026	38-1
SCTE-HMS-HE-FAN-MIB	117	84-3
SCTE-HMS-HE-POWER-SUPPLY-MIB	116	84-2

**Table #7: SCTE HMS MIBs Required**

# MAINTENANCE & TROUBLESHOOTING

## 5. Maintenance & Troubleshooting

### 5.1. Maintenance

Daily, ensure that the Power LED's are on for all of the modules and that there are no Alarm lights. Ensure that the yellow 'COM' LED near the rear RJ45 port is blinking.

Weekly, ensure that all module cooling fans are operational and unobstructed.

Monthly, vacuum all module cooling fans.

### 5.2. Troubleshooting

The following guide will help the operator to diagnose problems in active modules or chassis'. If none of the items in this section are of help, please contact ATX for Technical Support.

#### 5.2.1. Slow Flashing Red LED on Module Front

If any alarm LED on the front of the module is blinking at a rate of approximately 1 second ON, 1 second OFF, then this is indicative of a slot addressing communications failure. RF and Optical functionality will likely still work, but the unit will have no software monitoring or control during this time.

Try removing the module and replacing it. If this does not fix the problem, then switch the module to a different slot in the chassis. If the red LEDs return to normal operation, then the problem is in actual slot of the chassis and likely the connector on the back rail is damaged. Contact ATX and report a defective chassis.

If this does not fix the problem then contact ATX and report a defective module.

#### 5.2.2. Chassis' Yellow COM LED Not Blinking

It is normal for the round LED near the RJ45 port at the rear of the chassis to be solid ON or OFF during various states of system boot-up. If the chassis has been powered up (solid green on the round "+24V" LED near the terminal block at the rear of the chassis) for at least 2 minutes, then the yellow LED should be blinking to indicate the chassis software is running. If it is not, a reboot is necessary.

If the chassis can be interrupted briefly, then simply remove power to it by pulling all MPAC/MPDC modules out part-way.

If the chassis must remain live then try pressing the black RESET button near the RJ45 port. If this does not work, then the communications module itself can be removed from the back of the chassis. Remove the two Phillips screws that hold the module on, then pull it off and replace it. This will not interrupt the operation of the modules within the chassis.

If this still does not start the yellow LED blinking after boot-up, then a factory reset will be necessary (see Section 3.5.).

#### 5.2.3. No Response From Chassis Over Network

Typically, this is a 'subnet' issue. In order for any device to see another device on the same network, they must be on the same subnet. Consult your IT department for details of your network, but typically the subnet refers to the first three of the four octets in an IP address. E.g. if the computers in your network are given IP addresses of 192.168.10.1 through 192.168.10.250, then the subnet is the 192.168.10 part.

Each MAXNET II chassis ships with a default IP of 192.168.0.1, so the PC connected to it must have an IP address of 192.168.0.x where x is not equal to 1. This is not generally the case, so it must be forced.

To modify the PC's IP in Windows, choose Start -> Settings -> Network Connections -> Local Area Connection -> Properties -> Internet Protocol (TCP/IP).

If the chassis IP is no longer at the default IP, modify the subnet portions of these settings (IP address and Default Gateway) to match.

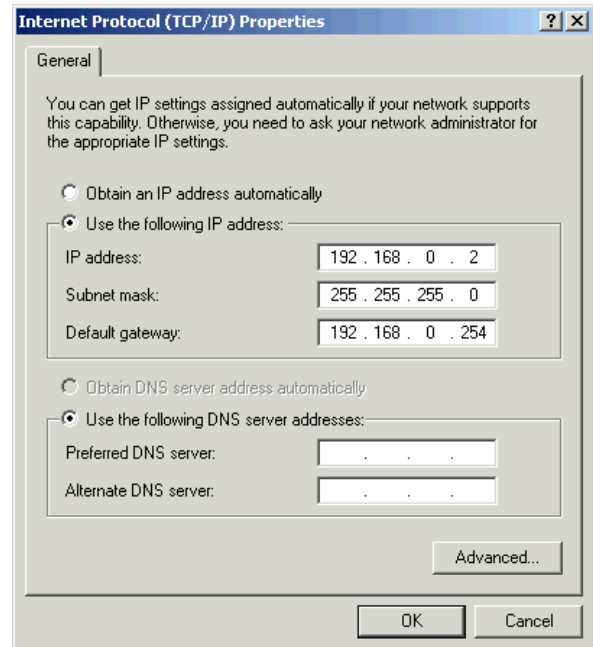

If the chassis is still not visible, it is possible the IP address of the chassis has been forgotten (see Factory Reset section), the network connection is not good (see Ethernet Port section for LED diagnostics) or a network port is blocked or firewalled (check with your IT department).

#### 5.2.4. Some Modules Do Not Show Up On Web Page

If the chassis is visible on the web or through SNMP walks, but one or more installed modules is not, try removing and replacing the module in a different slot. Verify that the green power LED is solid and the red LED is either off or blinking quickly (approx. half second on, half second off). If the LED's are not as stated, see the appropriate troubleshooting section.

#### 5.2.5. Module Power LED Off or Intermittent

Check the '24V' green LED on the rear of the chassis. If it is off, then the problem is that the chassis is not getting power. See MPAC/MPDC troubleshooting section. If it is on or if other modules in the chassis are okay, the module itself is suspect. Continue.

Remove the suspect module and trade slot positions with another functioning module.

- a) If the suspect module is okay and the previously good module fails, contact ATX and report a defective chassis.
- b) If the suspect module fails and the previously good module is okay, contact ATX and report that the suspect module is defective.

#### 5.2.6. MPAC/MPDC Not Powering Chassis

\*Note that 220 VAC applied to an MPAC-110 will damage the module, but 110 VAC applied to an MPAC-220 will simply not turn on.

- a) Check the fuse continuity on the MPAC or MPDC module.
- b) Verify that the 110 VAC / 220 VAC electrical outlet is active using a voltmeter and checking the circuit breaker. (In the case of the MPDC insure that there is -48 VDC on the rear terminal block)
- c) Verify that IEC power cord is properly inserted into the receptacle on the rear of the module and properly connected to an 110 VAC / 220 VAC electrical outlet.

### 5.2.7. Module Will Not Insert Fully Into Chassis

- a) Remove the module and inspect it for damage or bent guide rails.
- b) Inspect the chassis for bent metal or obstructions.
- c) Be sure that the active module is inserted such that the left side is above an odd numbered slot and the right side is above an even number slot.
- d) Try the module in a different slot. Due to machinery tolerances, some modules may be more snug in some slots than others. If the tolerances are unacceptable, contact ATX.

### 5.2.8. Temperature/Fan Fault Alarm on Any MAXNET® II Active Module

Check to see if the module fan is operating. If not replace with a new fan from ATX (Fan Part #: MPFANA) using the below procedure.



1. Remove two screws holding plate and fan in place.



2. Remove fan cover and screws.



3. Pull out fan with tweezers.

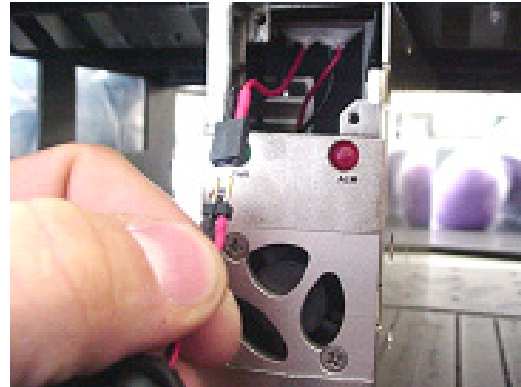

4. Remove push-fit power connections.

5. Install replacement fan in the opposite order shown. Ensuring that:
  - a) The red and black wires are aligned.
  - b) The labelled side of the fan faces inward toward the module.
  - c) The wires do not bunch up behind the fan, interfering with fan rotation.

This page left intentionally blank.

# SERVICE & SUPPORT

## 6. Service & Support

### 6.1. Contact ATX Networks

Please contact ATX Technical Support for assistance with any ATX products. Please contact ATX Customer Service to obtain a valid RMA number for any ATX products that require service and are in or out-of-warranty before returning a failed module to the factory.

ATX Networks  
1-501 Clements Road West  
Ajax, ON L1S 7H4 Canada

Tel: (905) 428-6068  
Toll Free: (800) 565-7488  
Fax: (905) 427-1964  
Toll Free Fax: (866) 427-1964  
Web: [www.atxnetworks.com](http://www.atxnetworks.com)  
E-mail: [support@atxnetworks.com](mailto:support@atxnetworks.com)

### 6.2. Warranty Information

All of ATX Networks' products have a 1-year warranty that covers manufacturer's defects or failures.

### 6.3. Safety

#### **IMPORTANT! FOR YOUR PROTECTION, PLEASE READ THE FOLLOWING:**

**Water and Moisture:** Care should be taken so that objects do not fall and liquids are not spilled into the enclosure through openings.

**Power Sources:** The device should be connected to a power supply only of the type described in the operating instructions or as marked on the device.

**Grounding or Polarization:** Precautions should be taken so that the grounding or polarization means of the device is not defeated.

**NOTE:** When installing the MPAC or MPDC Power Supply, the GND bonding terminal #1 on the back of the MPAC or MPDC Power Supply shall be connected to the chassis ground lug.

**Power Cord Protection:** Power supply cords should be routed so that they are not likely to be pinched by items placed upon or against them, paying particular attention to cords at plugs, convenience receptacles, and the point where they exit from the device.

**Servicing:** The user should not attempt to service the device beyond that described in the operating instructions. All other servicing should be referred to qualified service personnel.

**Fusing:** If your device is equipped with a fused receptacle, replace only with the same type fuse. Refer to replacement text on the unit for correct fuse type.

Recommended external fusing of the MPDC supply to be limited to 10 Amps.

The MPAC-110 Power Supply receptacle fuse rating is 6.3 Amps 250 Volts slo blo.

The MPAC-220 Power Supply fuse rating is 3.15 Amps 250 Volt slo blo.

**CAUTION: For continued protection against the risk of fire, replace only with the same type and rating of fuse.**

**Power Supply Removal:** Power (AC or DC) should be disconnected from the module before removing for replacement or service. This is accomplished by removing the AC IEC plug for the MPAC unit and the terminal block for the MPDC unit. To remove a power supply module from the chassis, gently lift the front handle and pull back on the module until it is clear of the chassis guide slot.



1-501 Clements Road West, Ajax, ON L1S 7H4 Canada  
Tel +1 (905) 428-6068 Toll Free +1 (800) 565-7488 Fax +1 (905) 427-1964 Toll Free Fax +1 (866) 427-1964  
[www.atxnetworks.com](http://www.atxnetworks.com) [support@atxnetworks.com](mailto:support@atxnetworks.com)