



DMDPCI

## Digital Phone Connect Solutions

### Digital Phone Connect Intercom Switch (DMDPCI):

#### General Overview:

- ▶ The DMDPCI Intercom Switch Solution is ideal for MDUs provisioned with No Subscriber Line (NSL) intercom products. It provides a one time switch-over from incumbent Telco to MTA-based service, as well as a conditions-based switch-back to Telco from the MTA service in the event of Telco/Intercom ring or MTA disconnection or power loss
- ▶ Ideal for MDU environments with NSL intercom solutions and/or applications where it is desirable to provide a seamless means with which to switch the premise wiring back to the Telco service
- ▶ Accommodate local number portability (LNP) without any customer down time
- ▶ Unique design minimizes false triggering due to noise picked up on premise wiring
- ▶ Unique configuration in a wall or table mount unit provides a clean installation into subscriber premises
- ▶ Third RJ11 jack accommodates local phone hook-up
- ▶ Switch reset functionality allows for re-deployment of product into other applications
- ▶ NOTE: cross connect wiring required at telco demarcation point (see Cross Connect Wiring Diagram, pg.2)

### DMDPCI Intercom Switch Specifications

SPECIFICATIONS	DMDPCI
<b>IMPLEMENTATION REQUIREMENTS</b>	
<b>CROSS CONNECT AT TELCO DEMARCATION</b>	See Cross Connect Wiring Diagram
<b>INPUT</b>	
<b>DC LINE VOLTAGE</b>	22 - 60 VDC (on R/G of MTA port)
<b>POWER UP TIME<sup>(1)</sup></b>	30 seconds max
<b>QUIESCENT CURRENT (MTA / TELCO)</b>	5.5mA/1mA
<b>OPERATION</b>	
<b>MTA / TELCO RING DETECTION</b>	40 VAC to 115 VAC
<b>SWITCH TO MTA / TELCO</b>	within 1-2 Ring cycles
<b>STATUS INDICATION</b>	LED Flashing Red = MTA Connected & Powered, Initial Install Mode, Switch in TELCO position LED Flashing Green = MTA Connected & Powered, Intercom Mode, Switch in MTA position LED Flashing Orange = MTA Connected & Powered, Intercom Mode, Switch in TELCO position LED Off = MTA Not Connected/Powered or off hook voltage too low <sup>(2)</sup>
<b>DEVICE RESET</b>	9 VDC applied across Y/B of phone jack
<b>OTHER</b>	
<b>TEMPERATURE</b>	-40°C to +60°C (-40°F to +140°F)
<b>SWITCH ISOLATION</b>	1000 Mohm @ 500 VDC applied for 1 minute
<b>SURGE WITHSTAND</b>	1500V Longitudinal, 800V Metallic IEEE CAT C62.41 Combination Wave on all ports & in both switch positions
<b>NOTES:</b>	
(1) Charge up time before device enters operational state.	
(2) In the event of multiple phones being off hook on an MTA call, it is possible that the DPCI will enter sleep mode. In this case the switch remains in MTA position. If the MTA is disconnected or loses power or is reset and not yet connected to a powered MTA, the switch will be in the TELCO position.	



DMDPCI

### Ordering Information

Part Number	Description
DMDPCI	Digital Phone Connect Intercom Switch

## Digital Phone Connect Intercom Switch (DMDPCI):

### Operational Functionality:

#### INITIAL INSTALL MODE OPERATION

DMDPCI switches premise wiring from incumbent Telco to MTA provided service on the first ring from the MTA. After initial switch-over from Telco to MTA device enters into **INTERCOM MODE**.

#### INTERCOM MODE OPERATION

DMDPCI maintains premises connection to MTA service until it detects a ring from the Telco service.

##### Scenario 1:

If ring from Telco is detected and user is on MTA call, call waiting tone is generated:

- User can flash over to Telco/Intercom call
- MTA call is maintained
- Once Telco/Intercom call is complete DMDPCI switches back to MTA

##### Scenario 2:

If ring from Telco is detected and user is not on MTA call:

- DMDPCI switches to Telco/Intercom
- If user does not answer and/or answers and completes the Telco/Intercom call the DMDPCI switches back to MTA

##### Scenario 3:

If MTA power is lost or MTA is disconnected:

- DMDPCI switches to Telco/Intercom until power from MTA is restored
- Upon detected return of MTA power the DMDPCI switches to MTA

##### Scenario 4:

9V applied across Phone Port B/Y (see schematic) of DMDPCI:

- DMDPCI switches back to Telco/Intercom and is set back to INITIAL INSTALL mode
- **Note: RESET is essential if device is to be used in a new MTA installation application**

### Device Functional Schematic

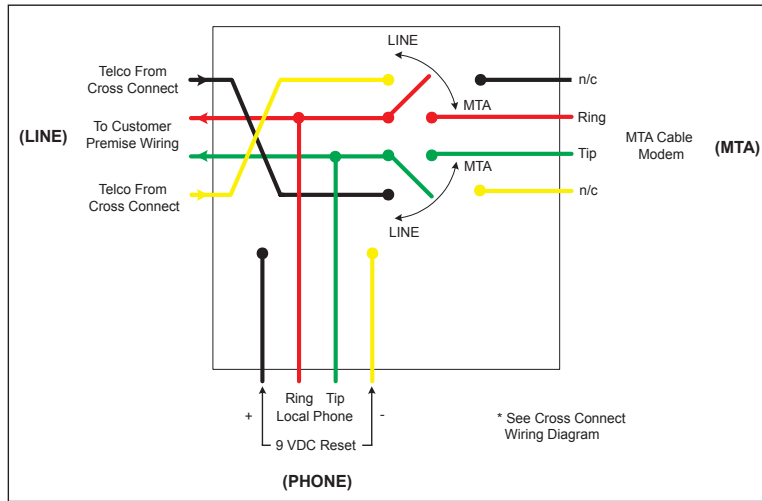

### Cross Connect Wiring Diagram

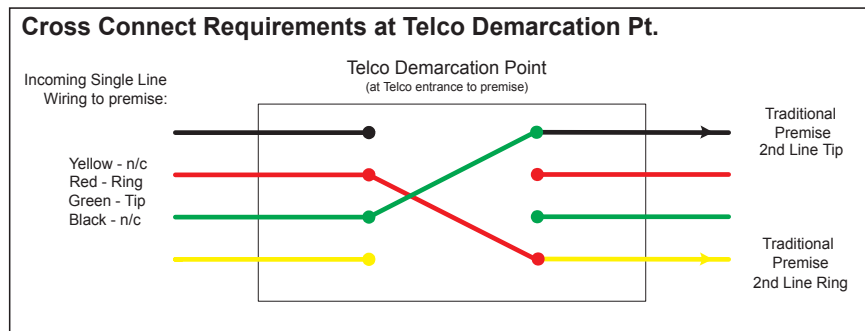

## Digital Phone Connect Intercom Switch (DMDPCI):

### Installation Instructions:

**NOTE: For proper operation, device must be mounted to a stable surface using screw-down tabs.**

1. Cross connect wiring at appropriate Telco demarcation point (see Telco Cross Connect Wiring Diagram, pg.2).
2. Using 4-wire UTP, connect Line port of the Digital Phone Connect Intercom Switch (DMDPCI) to premise wiring. Any RJ11 jack in premise can be used provided continuity has been assured.
3. Ensure DMDPCI is Reset. See reset instruction in # 8 below.
4. Connect Output of MTA to MTA port on the DMDPCI.
5. Ensure MTA is powered.
6. After approximately 30 seconds for the DMDPCI, the LED will start to flash RED indicating that the MTA is connected and the device is ready for operation.
7. Connect phone to Phone port of DMDPCI if desired.
8. **After device installation, ensure Telco dial tone is present before leaving subscriber premises.**
9. RESET: reset needs to be held for approximately 20 seconds until LED flashes RED.

### Installation / Wiring Configuration Information

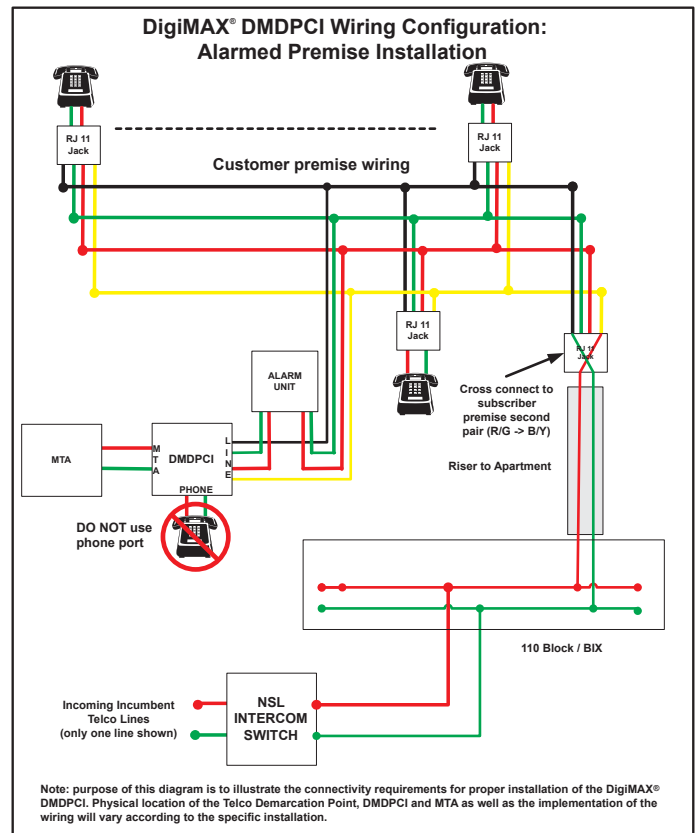
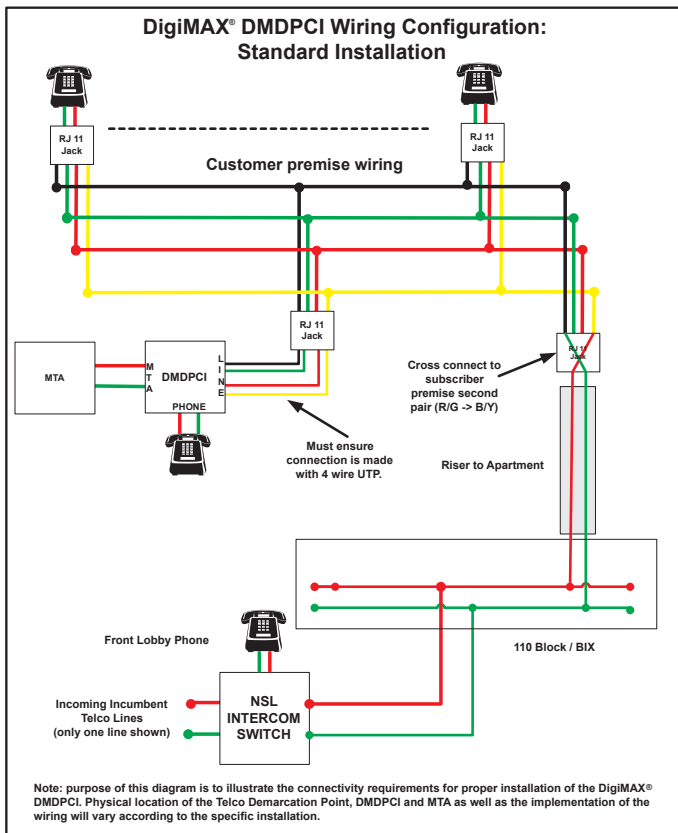

**Digital Phone Connect Intercom Switch (DMDPCI):**

**Installation / Wiring Configuration Information (cont'd)**

